

DAVIDSON, JUSTIN. (2019) 'Covert and overt attitudes towards Catalanian Spanish laterals and intervocalic fricatives'. In Whitney Chappell (ed.), *Recent Advances in the Study of Spanish Sociophonetic Perception*, John Benjamins, 39-84.
<<https://benjamins.com/catalog/ihl1.21.03dav>>

The following paper is an open-access version and as such has not undergone final formatting and page-numbering by the publisher. For a private copyrighted version (i.e., in order to cite direct quotes appearing on specific pages), email the author at justindavidson@berkeley.edu.

Davidson, J. (2019). Covert and overt attitudes towards Catalanian Spanish laterals and intervocalic fricatives. In W. Chappell (Ed.), *Recent Advances in the Study of Spanish Sociophonetic Perception* (pp. 39-84). Philadelphia, PA: John Benjamins Publishing.
<<https://benjamins.com/catalog/ihll.21.03dav>>

Covert and Overt Attitudes towards Catalanian Spanish Laterals and Intervocalic Fricatives

Justin Davidson

University of California, Berkeley

1. Introduction

This investigation examines covert and overt attitudes towards the Spanish of Catalonia, a unique variety of Spanish whose history of intense contact with Catalan provides an ideal case study for exploring the confluence of language use, linguistic ideologies, and ultimately, language variation and change in a multilingual community. Sociolinguistic treatments of Catalan-Spanish bilingualism traditionally center either on the contact features present in each language (cf. Arnal, 2011; Boix i Fuster & Vila i Moreno, 1998; Seib, 2001; Vann, 2001; Wesch, 1997) or on speakers' negotiation of Spanish and Catalan identities through language use and attitudes toward them (cf. Newman, 2011; Newman, Trenchs-Parera, & Ng, 2008; Trenchs-Parera & Newman, 2009; Vann, 1999; 2000; 2002; Woolard, 1984; 1989; 2009; 2011; Woolard & Gahgn, 1990). We build upon these lines of investigation, combining frameworks of dialectology and linguistic anthropology respectively, by empirically linking language attitudes towards specific linguistic features of Catalanian Spanish, and in so doing we demonstrate how broader linguistic attitudes and ideologies (i.e., towards languages) can be comprised from an aggregate set of individual speech variants and the social values afforded to each of these variants.

Adopting an expanded form of the Matched Guise Technique (cf. Lambert, 1967; Lambert, Hodgson, Gardner, & Fillenbaum, 1960), we empirically analyze covert attitudes towards variants of two of the most renowned phonetic variables of Catalanian Spanish (Casanovas Català, 1995, p. 56), both ascribed to Catalan influence, that are likely differentiated by degree of explicit awareness and may index distinct social meanings. The first, namely the velarization of alveolar /l/ to dark [ɫ] (e.g. *al parque* [aɫ.pár.ke] 'to the park'), was characterized by Sinner (2002, p. 163) as the only phonetic feature of Catalans' Spanish that speakers outside of Catalonia had explicit awareness of, whereas the second, namely the voicing of intervocalic voiceless /s/ to [z] (e.g. *los años* [lo.zá.nos] 'the years'), showed no such overt awareness outside of Catalonia. By combining covert attitudinal data with overt metalinguistic commentary on these speech features and Catalanian Spanish as a whole, we argue that velarized [ɫ] and intervocalic [z] respectively evidence a linguistic stereotype and indicator (cf. Labov 2001), and propose that the distinct social values associated with each variant can account for their differential use and evaluation in the diverse community of Spanish-Catalan bilinguals in Catalonia.

This paper is structured as follows: section 2 consists of a review of research concerning the evolution of linguistic attitudes of the Catalan-Spanish community and the phonetic variables presently under examination. Section 3 discusses our research questions and hypotheses with respect to the analysis of covert and overt attitudes towards Spanish [ɫ] and intervocalic [z]. Section 4 details the experimental methodology and test instruments. Section 5 discusses data analysis techniques and results from data collection. Section 6 offers a discussion of the results of the present study. Lastly, we conclude in section 7 by offering directions for future study.

2. Linguistic Attitudes and Speech Features in Catalonia

2.1. Matched Guise Studies in Catalonia

* This research would not have been possible without the generous hospitality and support provided by Antonio Torres Torres, Gemma de Blas, Ana María Fernández Planas (*Universitat de Barcelona*), Pilar Prieto and Mireira Trench-Parera (*Universitat Pompeu Fabra*), as well as Clara Cervera and the Martori family. I am additionally grateful for the helpful comments and insights offered by Itxaso Rodríguez-Ordóñez (Southern Illinois University) and two anonymous reviewers. All remaining errors are my own. Correspondences welcome: justindavidson@berkeley.edu.

In order to contextualize the study of linguistic attitudes in the Catalan-Spanish community, it is necessary to briefly detail the history of each language's presence and status there, which can generally be organized into four periods of unique language dynamics. First, until the union between Catalanoaragonese and Castilian kingdoms in 1469, Catalan was the common and by all practical considerations, the only and national language of the former's territories (Vallverdú, 1984, p. 19). The second period, from the formation of the Spanish Crown in 1469 and until the early 20th century, is marked by a very gradual introduction of diglossia and eventual Catalan-Spanish bilingualism in society, with Spanish being acquired initially only by ruling classes and intellectuals, and the popular classes and bourgeoisie remaining effectively monolingual in Catalan (Vallverdú, 1984, p. 20). Spanish only began to assume the role of the H language¹ (cf. Ferguson, 1959; Fishman, 1967) after the 1714 Ordinance of New Plant, legislation that suppressed all institutions and privileges of territories formerly part of the Catalanoaragonese Kingdom, and saw considerably accelerated and more widespread societal acquisition after the Moyano Law of 1857, which imposed compulsory public education in Spanish (Vila-Pujol, 2007, p. 62-63). The period from 1914 to 1975 is marked by considerable shifts in language status, with Catalan at first reclaiming its H status during nationalist political uprisings (*Mancomunitat* from 1914 to 1925, and *Generalitat* from 1931 to 1939) that brought about a powerful cultural revival of Catalan (Turell Julià, 2000, p. 46-47). The end of the Spanish Civil War in 1939, however, marked the start of a brutal subjugation of Catalan, which was stripped of official status and publically outlawed under the fascist and oppressive military regime of General Francisco Franco until his death in 1975. The final and current period of Spanish democracy, marked by the restoration of the Catalan Generalitat in 1977 and a national Constitution in 1978, is one in which Spanish is notably the only official national language of Spain, whereas Catalan, Basque, and Galician are permitted to be co-official alongside Spanish in the particular Autonomous Communities that choose to grant them co-officiality (Vila-Pujol, 2007, p. 68). Linguistic census data from 2013 shows that efforts to revitalize Catalan in Catalonia have been largely successful, with estimates of capacity for understanding, speaking, reading, and writing Catalan at over 94%, 80%, 82%, and 60% respectively, and more than 600,000 L1-Spanish speakers reporting Catalan as their habitual language (Institut d'Estadística de Catalunya, 2014).

Shortly after the reinstatement of the Generalitat in 1977, when the acquisition of Catalan by non-native speakers was still in its incipient stages², Woolard (1989, p. 38-39, as cited in Vann, 2007, p. 254-255) argues that the creation and expression of Catalan or Spanish identity was principally mediated (i.e., alongside birthplace, descent, and sentiment) by language use: "As a Catalan is one whose native and habitual language is Catalan, so a Castilian is a person whose native and habitual language is Castilian." The emphasis on habitual language use and indeed the mere ability to speak Catalan as foundations of Catalonian identity, reflect a real linguistic divide in the Catalan-Spanish community during the 20th century: "[w]hereas almost all Catalan speakers are bilingual in Castilian, the majority of Castilian speakers in Catalonia at the time of autonomy were monolingual or only passively bilingual" (Woolard & Gahng, 1990, p. 314). Accordingly, attitudes toward language use in the early 1980s were found to reflect this stark boundary between Spanish and Catalan identities.

Woolard (1984; 1989) conducted a matched guise experiment in Barcelona in 1980, repeated seven years later by Woolard & Gahng (1990), and repeated yet again in 2007 (Woolard, 2009; 2011) in which hundreds of high school students evaluated target guises, half dominant in Spanish and half dominant in Catalan, reading a mathematics text in Spanish and Catalan. With respect to solidarity attributes including "likeable," "amusing," "has a sense of humor," "open," "attractive," and "generous," in 1980 "...listeners rewarded linguistically identifiable co-members of their ethnolinguistic group for using their own language, and penalized them with significantly lower solidarity ratings when they used the out-group language" (Woolard, 2009, p. 133). In other words, as all listeners could detect which guises were Spanish-dominant and which were Catalan-dominant

¹ 'High' (H) language varieties are those that are afforded greater social prestige or linguistic capital than 'low' (L) varieties, which exemplify a more oral vernacular used in less formal settings.

² More than two million non-Catalonian immigrants moved to Catalonia between the years of 1950 to 1975, such that by the late 1970s, over 42% of the population of Catalonia ages 6 and older were Spanish immigrants (Arnal 2011: 13, 23; Gifreu 1983: 298; Strubell i Trueta 1984: 92; Woolard & Gahng 1990: 314). Fewer than half of all non-Catalonian immigrants learned to speak or write in Catalan after 1950 as a result of the prohibition of Catalan until Franco's death in 1975 (Vallverdú, 1991, p. 21).

(presumably based on salient auditory cues in Catalan-accented Spanish and Spanish-accented Catalan), Spanish-dominant listeners preferred the Spanish-dominant guises speaking in Spanish over Catalan, whereas Catalan-dominant listeners preferred Catalan-dominant guises speaking in Catalan over Spanish. This result can be understood as a preference for hearing unaccented or native-like Spanish or Catalan over L2- (accented) Spanish or Catalan. While neither listener group showed considerable differences in ratings between the languages of out-group guises (i.e., Catalan-listeners were unaffected by which language they heard Spanish-dominant guises use, and Spanish-dominant listeners were unaffected by which language they heard Catalan-dominant speakers use), it was additionally noted that Spanish-dominant listeners particularly disapproved of Spanish-dominant guises speaking in Catalan, interpreted as a kind of ethnolinguistic group betrayal (Newman et al., 2008, p. 309; Woolard & Gahng, 1990, p. 315).³

By 1987, however, although the preference for unaccented speech was still found for both listener groups, two noticeable differences in solidarity trends were found. First and foremost, Spanish-dominant listeners no longer severely penalized Spanish-dominant guises for speaking in Catalan. Second, Catalan-dominant listeners were no longer indifferent to the language production by Spanish-dominant guises, and awarded higher solidarity ratings for the (L2) Catalan usage. These changes were interpreted as the beginning of a breakdown of the ethnolinguistic boundary that had previously discouraged Catalan usage by Spanish-dominant speakers as reflected in the poor solidarity ratings by Spanish-dominant listeners and the ambivalent ratings by Catalan-dominant listeners (Woolard, 2009, p. 133; Woolard & Gahng, 1990, p. 315). In other words, by 1987, the use of Catalan by Spanish-dominant speakers was no longer ostracized by Spanish-dominant listeners, and was in fact favorably perceived by Catalan-dominant listeners, suggesting that the adoption of Catalan in habitual use by Spanish-dominant speakers was at last perceived positively in the (youth) community.⁴

In 2007, solidarity scores between the two languages were not distinct for any of the listener groups. In other words, the use of Catalan or Spanish no longer affected how listeners assigned solidarity attributes for each guise, suggesting that listeners no longer preferred guises to use one language instead of the other. The lack of a preference (or perhaps more importantly, the lack of a penalty) for a speaker to use Catalan or Spanish represents the final stage in the loosening of the link between language and ethnolinguistic identity, as the use of Spanish or Catalan is no longer viewed as a fixed or nonflexible component of one's ethnolinguistic identity: "The division in Catalan versus Spanish identities and ideologies is [no longer] based on habitual choice of language" (Vann, 2007, p. 264). The results across all three studies are perhaps best summarized succinctly by Woolard (2009, p. 147):

"Language affiliations are viewed by these young people even more than those in past years as the exercise of options, as stylistic choices that individuals can and do make, rather than as enduring essential characteristics. [...] Overall, these findings show that there is increased bilingualism, a broadened acceptance of the Catalan language, and an accompanying expansion of Catalan identity among these young people compared to their counterparts of twenty years ago."

Given the current state of widespread bilingualism in Catalonia as evidenced in the aforementioned linguistic census statistics, which substantiate Arnal's (2011, p. 15) claim that "...Catalan ha[s] ceased to be a language reserved exclusively for internal use by the group of native Catalan speakers, and ha[s] been adopted for habitual use at work or with friends by some speakers whose first language [i]s Spanish," it follows that the absence of disdain for L2- (accented) speech found in Woolard's 2007 study can be interpreted as indicative of the acceptance of active Catalan-Spanish bilingualism. In fact, using a similar matched guise methodology in 2006, Newman et al. (2008) found that non-native guises (i.e., Spanish-dominant speakers using Catalan and Catalan-

³ Newman et al. (2008, p. 309) argue that this 'linguistic betrayal' was only available for Spanish-dominant listeners as a reflection of the asymmetric bilingualism in society. Since most Spanish-speakers were monolingual, their use of Catalan implied a shift from monolingualism to bilingualism. The same could not be said for Catalan-speakers, who were already bilingual in Catalan and Spanish.

⁴ Shortly thereafter, Sanz i Alcalà (1991, p. 125, 134-135) obtained corroborating results for a similar matched guise study on Spanish with Barcelonan youth (ages 17-18) speakers, in that nearly half of listeners (49%) couldn't tell the difference between the Catalan-dominant and Spanish-dominant guises in Spanish, although Catalan-dominant listeners awarded higher solidarity scores to the Catalan-dominant guises.

dominant speakers using Spanish) were rated higher in solidarity attributes than native guises. Newman et al. (2008), Trenchs-Parera & Newman (2009), and Newman (2011) describe this preference as *linguistic cosmopolitanism*, linking it to a modern ideology supportive of bilingualism and language transfer: “Linguistic Cosmopolitans support multilingualism as a marker of acceptance of the ethnolinguistically heterogeneous society that they value. For people holding this ideology, the in-group/out-group dynamic breaks down because they do not see group membership as a proper motive for assessing social attractiveness” (Newman, 2011, p. 41). Accordingly, the acceptance of (and even the preference for) active bilingualism by both native speakers of Catalan and native speakers of Spanish underpins one of the more modern and currently prevalent linguistic ideologies in Barcelona and Catalonia more generally.

As previously mentioned, in all of these matched guise research lines, the dominant language of particular target guises was presumably ascertained on the part of participants by the presence of L1-like or L2-like acoustic features in each of Spanish and Catalan. While this broader focus on an aggregate presence of speech features more closely approximates natural Spanish and Catalan speech, it cannot link participants’ attitudes towards specific speech variants, which may be differentially evaluated despite their persistent co-occurrence in real speech. For example, while Catalan-accented Spanish may be generally evaluated positively within the Catalan-Spanish community, it may be the case that these evaluations are more strongly associated with certain speech variants more than others, or that while some (or even a majority) a speech features are judged positively, others nonetheless are evaluated negatively. Moreover, it is unclear which particular speech features are salient and overtly recognizable by speakers, and which remain beneath conscious or explicit awareness. In order to answer these questions, which shed light on the relationship between individual speech features and the evaluation of their aggregate whole (i.e., a linguistic variety), in the present study we more narrowly focus on attitudes towards the specific speech variants of two phonetic variables, which we detail in the following subsection.

2.2. Laterals and Intervocalic Fricatives in Spanish and Catalan

Two Spanish phonetic features frequently ascribed to contact with Catalan are the velarization of the voiced alveolar lateral /l/ to dark [ɫ] and the voicing of the voiceless alveolar fricative /s/ to voiced [z] in intervocalic contexts (Badia i Margarit, 1964, p. 152; Pieras, 1999, p. 212-213; Serrano Vázquez, 1996, p. 378-379; Vann, 2001, p. 124; Wesch, 1997, p. 296, 298). Prescriptive characterizations of (monolingual) Spanish and Catalan, with respect to alveolar lateral production, distinguish the former as exclusively exhibiting a non-velarized or light (or clear) [l], articulated by creating a tongue-tip occlusion at the alveolar ridge while maintaining a non-obstructed airstream around the side(s) of the tongue (Dalbor, 1997, p. 251; Hualde, 2014, p. 177-178; Navarro Tomás, 1918, p. 88; Morgan, 2010, p. 331; Schwegler, Kempff, & Ameal-Guerra, 2010, p. 297-299). Catalan, on the other hand, is characterized as exclusively exhibiting a velarized or dark [ɫ], articulated with an additional constriction of the tongue body toward the velum (Badia i Margarit, 1984, p. 103-104; Hualde, 1992, p. 373, 396; 2014, p. 178; Prieto, 2004, p. 204; Wheeler, 2005, p. 34).

With regard to intervocalic fricative production, prescriptive characterizations of (monolingual) Northern-Central Peninsular Spanish note the exclusive presence of voiceless apical-alveolar [s] (from a single voiceless alveolar fricative phoneme /s/), articulated with a gesture of the tongue-tip toward the alveolar ridge (Dalbor, 1997, p. 225; Hualde, 2014, p. 147-148, 155; Martínez Celdrán & Fernández Planas, 2007, p. 110; Morgan, 2010, p. 248; Navarro Tomás, 1918, p. 83; Schwegler et al., 2010, p. 171). Catalan, on the other hand, is claimed to feature voiced apical-alveolar [z] in intervocalic contexts: syllable-initially, /s/ and /z/ contrast phonemically, resulting in minimal pairs such as *pesar* [pə.zá] ‘to weigh’ and *passar* [pə.sá] ‘to pass,’ whereas word-finally, these phonemes neutralize and yield voiced [z] via regressive voicing assimilation, as evidenced by *gos* [gós] ‘dog’ and *gos aquí* [gó.zə.kí] ‘dog here’ (Bonet & Lloret, 1998, p. 118-119; Hualde, 1992, p. 371-372, 393-394; Prieto, 2004, p. 208; Wheeler, 2005, p. 147-149, 162).⁵

The selection of these particular speech features, beyond their characterization as “*los dos rasgos más sobresalientes de las producciones fonéticas en el español de un catalanohablante* (the two most

⁵ Word-final intervocalic fricative voicing in Catalan can produce some minimal pair phrases, such as *les oques* [lə.zó.kəs] ‘the geese’ and *les soques* [lə.só.kəs] ‘the logs’ (Arnal, 2011, p. 19), and *les ales* [lə.zá.ɫəs] ‘the wings’ and *la sales* [lə.sá.ɫəs] ‘2.sg. salt it’.

prominent features of the phonetic production of Spanish by a speaker of Catalan)” (Casanovas Català, 1995, p. 56), is additionally motivated by a likely difference in their social evaluation and degree of overt awareness. Sinner (2002) conducted 52 interviews with Barcelonan Catalan-Spanish bilinguals and Madrid Spanish monolinguals regarding phonetic, morphological, and syntactic features of Catalanized Spanish of which they were aware, as well as their opinions on the Spanish of Catalan speakers. In contrast to [z], only named by Barcelonan bilinguals, both Madrid monolinguals and Barcelonan bilinguals named [ɫ], one of only two features (the other being the use of definite articles such as *el* or *la* before given names [e.g. *la Sofía, el Marcos*]) of which speakers were overtly aware outside of Catalonia. Madrid speakers reported knowledge of [ɫ] from television and radio shows that parodied Catalans and their Spanish. Moreover, Madrid interviewees commented that Catalans use less Spanish vocabulary than other Spaniards, and that their Spanish is of a poorer quality than that of other Spaniards, describing it as “*muy de pueblo, muy raro*” ‘much like from the countryside, very strange,’ “*una pronunciación dura, áspera*” ‘a harsh, rough pronunciation,’ and “*feo, nada bonito, muy agresivo, [sin] la gracia que tiene el español de aquí*” ‘ugly, not pretty at all, very aggressive, without the elegance of the Spanish here’ (Sinner, 2002, p. 165). Barcelonan interviewees admitted to feeling an overt obligation to correct or adjust their Spanish pronunciation when speaking in public, and described Catalans’ Spanish as “*rústico*” ‘rustic’ (Sinner, 2002, p. 166).

It is possible that the aforementioned negative evaluations of Catalans’ Spanish, at least on the part of Madrid interviewees, principally reflect the use of [ɫ], since this was the only pronunciation that they overtly named. Such a hypothesis finds corroboration in characterizations of [ɫ] in the Spanish of Palma de Majorca as a linguistic stereotype, in that youth and female speakers were found to avoid [ɫ] in comparison to older and male speakers, accounted for by an overt stigma associated with [ɫ] as indexing rurality, old age, and low social class (Pieras, 1999; Simonet, 2010a; 2010b). The present study shall resolve this question with attitudinal data targeting each of [ɫ] and [z] individually, and provide insight as to whether or not explicit awareness of these features and attitudes towards Catalans’ Spanish in general have changed since Sinner’s (2002) earlier work, especially as related to linguistic cosmopolitanism (cf. Newman, [2011], Newman et al., [2008], and Trenchs-Parera & Newman, [2009]).

3. Research Questions and Hypotheses Concerning Catalans’ Spanish [ɫ] and [z]

In order to assess attitudes toward Catalanian Spanish and specific phonetic features that comprise it, this study puts forth the following three research questions:

- RQ1)** What covert attitudes are linked to the production of Catalanian Spanish /l/ as either [l] or [ɫ]?
- RQ2)** What covert attitudes are linked to the production of Catalanian Spanish intervocalic /s/ as either [s] or [z]?
- RQ3)** What overt attitudes are linked to Catalanian Spanish /l/ production, /s/ production, and Catalanian Spanish as a whole?

Sinner (2002, p. 165-166) reported that attitudes towards Catalanian Spanish were generally negative, and thus we may find that both [ɫ] and [z] are disfavored over [l] and [s], with the former variants indexing uneducated, rural, incorrect, or generally unpleasant-sounding speech. However, since lateral production (as [ɫ]) was the only phonetic feature of Catalanian Spanish identified by speakers within and outside of Catalonia, it is possible that negative evaluations of [z] production may simply be absent altogether, or if present, be exclusively covert, whereas (negative) evaluations of [ɫ] may be both covert and overt.

Alternatively, at least with respect to the attitudes of Catalan-Spanish bilinguals, it is possible that neither [ɫ] nor [z] production is afforded negative social value, and instead is even evaluated positively. Matched guise research by Woolard (2009; 2011), Newman et al. (2008), Trenchs-Parera & Newman (2009), and Newman (2011) suggest that Catalan-accented Spanish is nowadays esteemed favorably by Catalan-Spanish bilinguals, indicative of a preference for active bilingualism or linguistic cosmopolitanism in which language transfer phenomena index a modern, communal bilingual identity. Accordingly, attitudes towards [ɫ], [z], and Catalanian Spanish in general may vary according to the bilingual status of the listener, resulting in (more) favorable judgments by Catalan-Spanish bilinguals

and less favorable evaluations by monolingual outsiders from Madrid. Furthermore, it is also possible for positive evaluations of Catalanian Spanish to exist alongside negative evaluations towards specific speech features of Catalanian Spanish (such as [ɫ]), which would suggest that global attitudes towards speech varieties reflect a complex amalgamate of feature-by-feature attitudes.

4. Experimental Methodology

4.1. Matched Guise

In order to indirectly elicit social evaluations of [ɫ] and intervocalic [z] in Catalanian Spanish, we implemented a matched guise experiment (cf. Lambert, 1967; Lambert et al., 1960) that targeted each phonetic variable (/l/ and /s/) individually, allowing for comparisons between the two. As will be detailed, participants heard two pairs of target guises, namely one with exclusively [ɫ] and one with exclusively [l], as well as one with exclusively [z] and one with exclusively [s]. The lateral pair of guises (i.e., [ɫ] vs. [l]) had no tokens of word-final intervocalic /s/, and in parallel the fricative pair of guises (i.e., [z] vs. [s]) contained no laterals whatsoever, permitting a more independent evaluation of the covert social values afforded to the variants of each variable. Notably, this appropriation of the matched guise technique (following Campbell-Kibler [2007] and Barnes [2015]) elicits attitudes specifically towards variants of /l/ and /s/, in contrast with previous studies in Catalonia (cf. Newman, 2011; Newman et al., 2008; Woolard, 1984; 1989; 2009; 2011; Woolard & Gahng, 1990) that focused on attitudes towards monolingual-like Spanish and Catalanian (or Catalan-accented) Spanish more globally, without reference to any particular speech feature. Moreover, with respect to the exclusive focus on word-final intervocalic contexts for /s/, the rationale is two-fold. First, since lateral velarization is strictly phonetic, the word-final context for intervocalic /s/ allows for a more uniform comparison of phonetic phenomena, since the syllable-initial context for intervocalic /s/ is a site of phonemic contrast in Catalan. Second, [z] production outside of the word-final intervocalic context has been shown to be extremely infrequent if not categorically absent in Catalanian Spanish compared to the word-final intervocalic context (e.g. 42% word-finally vs. 0% syllable-initially [Davidson, 2015, p. 135]), and thus a focus on word-final contexts more accurately represents natural speech.

4.1.1. Guise Stimuli

Two target reading passages (see appendix A) were created, namely a lateral passage and a fricative passage, respectively featuring 10 instances of /l/ or word-final intervocalic /s/ and 0 instances of word-final intervocalic /s/ or /l/. The passages were of uniform length (respectively 80 and 78 words long), were roughly 29 seconds long when read aloud, featured the target phoneme as roughly 3% of the total phonemes in each, and were neutrally themed. Though /l/ (in the lateral passage) and intervocalic /s/ (in the fricative passage) each appear in a variety of unique linguistic contexts, approximating their actual (heterogeneous) distribution in more natural speech, the majority of lateral and intervocalic fricative tokens nonetheless appear in linguistic contexts that have been found to favor (respectively) velarization and voicing, so that the eventual use of exclusively [ɫ] or [z] in each passage more closely could approximate natural speech (i.e., even if a half-minute of natural speech does not typically exhibit exclusively [ɫ], the most probable occurrence of a string of exclusively [ɫ] realizations of /l/ would be one with phonological contexts that condition velarization the most). To this end, following Davidson (2012; 2014; 2015), at least half of the laterals (in the lateral passage) appear word-finally and in the context of a preceding non-front vowel and following velar consonant or pause, whereas at least half of the word-final intervocalic fricatives (in the fricative passage) appear in the context of at least one unstressed adjacent vowel.

The two target reading passages were spoken by a trained, Catalan-Spanish bilingual female phonetician (L1-Catalan) in her twenties, instructed to read each as naturally (i.e., casually) as possible while adhering as much as possible to standard Spanish, monolingual-like norms, in an audiometric soundproof booth.⁶ These two recordings, henceforth referred to as the lateral and fricative templates,

⁶ The first decision to be made regarding speech stimuli in any matched guise task is whether to record spontaneous speech or record speech read from a text designed by the researcher, as is traditionally done in matched guise research. The former option avoids confounds of read vs. natural speech (pertaining to discernable differences in prosody, speech rate, length and placement of pauses in read speech [Campbell-Kibler, 2006, p. 83]), whereas the latter option allows the researcher to have substantially greater control over the contexts in which linguistic variables occur, eliminate differences in word-choice and passage length between guises, and

served as the base recordings onto which uniformly velarized or non-velarized and uniformly voiced or voiceless target phones would be spliced, creating two identical lateral passages except for the ten /l/ tokens spliced in, and two identical fricative passages except for the ten /s/ tokens spliced in. Accordingly, the goal was to obtain template passages of /l/ and intervocalic /s/ that, ignoring these two features, exhibited as few (if any) features of Catalan-accented speech as naturally possible, such that ideally only differences in /l/ and /s/ production would substantiate different covert judgments for each guise on the part of listeners.

In order to obtain tokens of [ɫ], [l], [z], and [s] to splice onto the lateral and fricative templates, the lateral passage and fricative passage were read aloud several more times as monolingual-like as possible and as Catalan-accented as possible. Ten tokens each of [ɫ] and [z] were sought out in the Catalan-accented renditions, whereas tokens each of [l] and [s] were sought out in the monolingual-like renditions and individually segmented out in Praat (Boersma & Weenink, 2018), taking additional care to select tokens that appeared in words and phrases with pitch contours that were maximally similar to those in the template recordings in order to best facilitate natural-sounding splicing.

The identification of discretely velarized or non-velarized laterals, as well as discretely voiced or voiceless fricatives, is a somewhat complicated endeavor. Both lateral velarization and fricative voicing are most often considered gradient phenomena, measured respectively on a continuous scale of second formant (F2) values (inversely related to velarization degree) or a continuous scale of percentage of segment duration with voicing (cf. Chappell & García, 2017; Gradoville, 2011; Recasens, 2004; 2012; Recasens & Espinosa, 2005; Recasens, Fontdevila, & Pallarès, 1995; Romero, 1999; Simonet, 2010a; 2010b; Torreira & Ernestus, 2012). Still, velarization and voicing thresholds have been reported with some frequency in the literature, likely reflective of a speaker's categorical (and cross-linguistic) perception of a lateral as either light or dark or of a fricative as either voiced or voiceless (Proctor, 2009, p. 62). For laterals, by far the most common threshold reported (calculated from Central Catalan and Spanish laterals) is that of approximately 1500hz, such that the F2 of a prototypical [ɫ] is below 1500hz, whereas the F2 of a prototypical [l] is above 1500hz (Martínez Celdrán & Fernández Planas, 2007, p. 136; Quilis, 1981, p. 276; Recasens, 1986, p. 95, 102; 1996, p. 65; 2004, p. 600; 2014, p. 178; Recasens & Espinosa, 2005, p. 3, 6; Recasens et al., 1995, p. 42). Other characterizations of light and dark laterals in Catalan and Spanish don't stray particularly far from this 1500hz threshold. For instance, Pieras (1999, p. 220) and Recasens (1991, p. 306; 2012, p. 369) both characterize [l] as exhibiting an F2 of at least 1500hz, whereas [ɫ] typically exhibits an F2 of roughly 1000 to 1200hz. These F2 boundaries were in fact found to accurately reflect Spanish alveolar lateral production by Barcelonan bilinguals in Davidson (2014, p. 232), wherein F2 values were most commonly either above 1500hz or below 1200hz. Accordingly, for the present methodology, individual /l/ tokens were identified as light or dark (as a relative opposition, akin to 'lighter' [l] and 'darker' [ɫ]) if they exhibited an F2 value greater than 1500hz or less than 1200hz, respectively. The average F2 of the 10 selected [l] tokens was 1681hz, whereas the average F2 of the 10 selected [ɫ] tokens was 1048hz. This constitutes an average difference in F2 (between what we are considering as dark and light laterals) of over 600hz, or more than double the 300hz distance reported in the aforementioned Catalan and Spanish research. Accordingly, though we are not presently claiming a categorical threshold between [ɫ] and [l], the laterals we shall henceforth consider as [ɫ] or [l] show a substantial average F2 difference between them, more than enough to be perceived as acoustically distinct by listeners and thus treated by them as discrete examples of a dark [ɫ] and a light [l].

In parallel, for Spanish fricatives, voicing thresholds to distinguish [z] from [s] are relatively common in the literature. Campos-Astorkiza (2014, p. 21-23) found that the majority of Spanish /s/ productions observed exhibited voicing durations of either less than 20% ([s]) or greater than 90% ([z]) of the segment's duration, whereas Davidson (2015, p. 131) observed the majority of /s/ productions produced by Catalan-Spanish bilinguals to exhibit voicing durations of less than 30% or greater than 60%. Others, such as Schmidt & Willis (2011: 6) and Escalante (2016, p. 34), have identified fixed thresholds of 60% voicing duration and 50% respectively, whereas Hualde & Prieto (2014, p. 8), Torreira & Ernestus (2012, p. 136), and Chappell & García (2017, p. 17) focus on tokens

incorporate neutral, non-topically-biased speech content. Ultimately, our decision to record read speech reflected the need to ensure that the linguistic phenomena under study were mutually exclusive in guise stimuli. Moreover, the stimuli were first presented to 5 native, non-linguist speakers of Spanish to elicit comments on their naturalness, none of whom remarked that any sounded unnatural or strictly read.

with 100% voicing duration, namely irrefutable cases of Spanish (and/or Catalan) [z]. Though we applied the threshold of 30% and 60% observed for Catalan-Spanish data by Davidson (2015) for the present identification of [z] and [s] productions, it should be noted that the average voicing duration of the 10 selected [s] tokens was 11% in comparison to the average voicing duration of the 10 selected [z] tokens, which was invariably 100%. This constitutes an average difference in voiced segment duration between /s/ tokens considered to be voiceless and voiced of nearly 90%, consistent with all of the previously reported thresholds and more than enough to be perceived as acoustically distinct by listeners and treated by them as examples of a voiced [z] and a voiceless [s].

Once the 40 fricatives and laterals (10 of each type) were identified and removed from their original contexts, they were spliced onto the templates to create the four target guises (i.e., one with 10 [ɬ] tokens vs. one with 10 [l] tokens, and one with 10 [z] tokens vs. one with 10 [s] tokens). As for the splicing of laterals, following Campbell-Kibler (2006, p. 88-89), we identified boundary points by using an adjacent pause, stop closure, or stable point in a sonorant. As for the splicing of fricatives, we manually marked left and right boundaries for each /s/ segment by using both the waveform and spectrogram to respectively find the zero-intercept in the waveform closest to the first and last signs of aperiodic noise in the spectrogram (cf. Campos-Astorkiza, 2014, p. 21; Erker, 2012, p. 56-57; File-Muriel & Brown, 2011, p. 227-228; Schmidt & Willis, 2011, p. 6). For all splices, audible changes in intensity, segment duration, and/or pitch (in comparison with the original /l/ and /s/ productions of the templates themselves) were manually adjusted to restore natural sounding speech. Beyond these global adjustments, two additional modifications were performed. First, for laterals, a minority of spliced [l] tokens and a majority of spliced [ɬ] tokens were unable to be directly inserted into the template and remain natural-sounding due to a lack of a natural vocalic transition. In other words, as suggested in Recasens (1986; 1991; 2004; 2012; 2014), Recasens & Espinosa (2005), Recasens et al. (1995), and Vann (2001), the vowel preceding /l/ is colored by the lateral's degree of velarization, such that a formant transition from a vowel originally preceding a light [l] to a spliced dark [ɬ] is extremely unnatural-sounding. Because of this complication, the affected lateral tokens were instead spliced out with their preceding vowel into the template passage. Thus, in order to maximize the naturalness of the guises, we were forced to forgo a strict synthesis of minimal pair recordings for lateral guises, differing strictly exclusively in /l/ segments, in favor of a synthesis of /l/ guises differing in either the combination of lateral segments and vowel + lateral sequences (i.e., spliced rhymes) or lateral segments (i.e., spliced /l/). Second, for fricatives, in light of the frequently attested cross-linguistic finding of a negative correlation between voicing degree and length of fricative segment (cf. Gradoville, 2011; Hualde & Prieto, 2014; Rivas, 2006; Schmidt & Willis, 2011; Stevens, Blumstein, Glicksman, Burton, & Kurowski, 1992; Torreira & Ernestus, 2012), the segment length of spliced [z] tokens in the voiced guise was not adjusted to match the duration of the equivalent [s] token in the voiceless guise, and instead reflected the original proportion of segment duration between [s] and [z] prior to insertion into the templates, such that on average, [z] tokens were one-third shorter in overall duration than their [s] equivalent tokens in the voiceless guise. Below, in figures 1 and 2, we present examples of the spectrograms of synthesized [l], [ɬ], [s], and [z] tokens for a given excerpt of each target guise. For ease of visual comparison, each figure displays a horizontal juxtaposition of parallel /l/ and /s/ tokens, with a highlighted separation of silence in the middle.

Figure 1 Spectrogram Analysis of [l] (~1664hz) and [ɬ] (~1100hz) in *al final decidi*

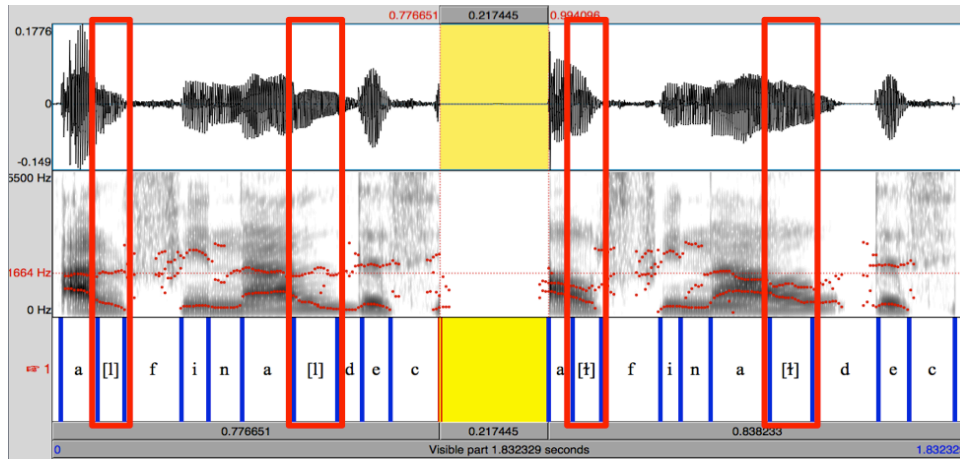
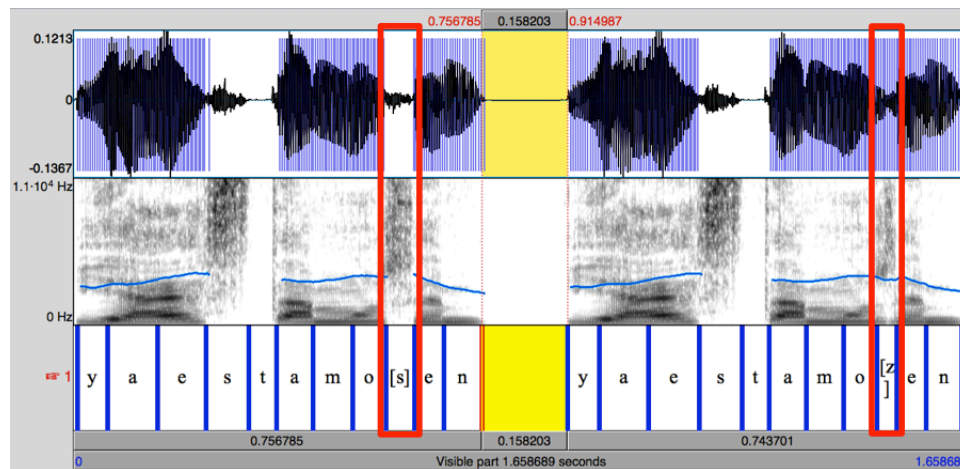

Figure 2 Spectrogram Analysis of [s] (~9% voiced) and [z] (100% voiced) in *ya estamos en*



4.1.2. Presentation of Guise Stimuli

Given the increased opportunity for listeners to realize that target guises were produced by the same speaker, as each guise pair differed in only a set of 10 isolated sound segments, a set of four filler passages (see appendix A) was created, each with a word length (~ 80 word), duration (~29 seconds), and neutrally-themed content parallel to the four target guises. To maximally mask the target guises' repeated voice, the four filler passages (in which /s/ and /l/ appeared simultaneously across various linguistic contexts, since it was infeasible to construct passages lacking both /s/ and /l/) were recorded by a total of eight native speakers of Spanish (two speakers per filler passage) representing a wide range of non-Catalonian Spanish dialects (e.g. Argentinean Spanish, Puerto Rican Spanish, Colombian Spanish, Andalusian Spanish, Mexican Spanish, Basque Spanish, Galician Spanish, and Venezuelan Spanish). Thus, listeners would hear six unique passages (e.g. lateral passage, fricative passage, first filler, second filler, third filler, fourth filler), each appearing twice (i.e., [ʔ] target guise ~ [l] target guise, [z] target guise ~ [s] target guise, first filler speaker 2 ~ first filler speaker 3, second filler speaker 4 ~ second filler speaker 5, third filler speaker 6 ~ third filler speaker 7, fourth filler speaker 8 ~ fourth filler speaker 9), constituting a total of 12 audio files to be evaluated per listener. To further reduce the possibility for a listener to identify the four target guises as a single repeated voice, the filler and target guises were maximally distanced from one another in the sequence of twelve recordings and additionally separated into two rounds of six recordings. Listeners would complete the first sequence of six recordings, then fill out a socio-demographic questionnaire (allowing time to forget voices and passages), and finally complete the second round of remaining six recordings. Moreover, the order of target guise presentation was balanced amongst eight blocks to eliminate priming as a possible

confound. The presentation of matched guise stimuli is presented visually in figure 3 below, with S denoting unique speakers, A/B/C/D denoting each of the four filler passages, and block orders of target guises appearing in horizontal rows.

Figure 3 Presentation of Matched Guise Stimuli

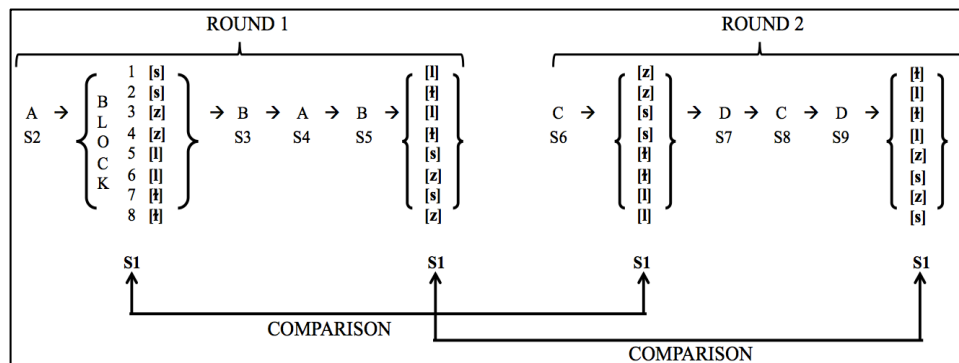

4.1.3. Matched Guise Questionnaire

Listeners indicated covert judgments of matched guise stimuli according to a series of Likert and semantic-differential scales from 1 to 7, each preceding *Pienso que esta persona (es)...* ‘I think that this person (is)...’ (see appendix B). These test items were selected in accordance with prior work concerning attitudes towards Catalanian Spanish (cf. Newman et al., 2008; Sinner, 2002; Woolard, 1984; 1989; 2009; 2011; Woolard & Gahng, 1990), and covered the following set of five attributes: (1) solidarity (i.e., social attractiveness as related to being amusing, likeable, physically attractive, sensitive, generous, and open [Newman, 2011, p. 40]), via *simpático-antipático* ‘nice/mean,’ *agradable de escuchar-desagradable de escuchar* ‘pleasant/unpleasant to listen to,’ and *sería mi amigo fácilmente-no sería mi amigo fácilmente* ‘would/would not easily be my friend’; (2) power (i.e., a level of respect as related to being intelligent, cultured, self-confident, hardworking, a leader, and trustworthy [Newman, 2011, p. 40]), via *tiene estudios-no tiene estudios* ‘educated/uneducated,’ *tiene un trabajo que le pagan bien-tiene un trabajo que le pagan mal* ‘has a high-/low-paying job,’ and *fiable-dudoso* ‘trustworthy/untrustworthy’; (3) accent (i.e., prescriptive evaluation of how correct or proper the speaker’s Spanish is) via *sabe hablar castellano bien-no sabe hablar castellano bien* ‘knows/doesn’t know how to speak Spanish well’ and *tiene un acento bonito-tiene un acento feo* ‘has a pretty/ugly accent’; (4) rurality (i.e., judgment of the speaker as hailing from an urban center vs. a rural village) via *de la ciudad-del campo* ‘from the city/countryside’; and (5) bilingualism (i.e., judgment of the speaker’s status as a speaker of Catalan) via *también habla catalán-sólo habla castellano* ‘also speaks Catalan/only speaks Spanish.’ Additional filler items for the speaker’s status as bilingual in Spanish and another language (like Basque, etc.) were additionally used to lessen the perceived emphasis of the investigation as pertaining to Catalanian Spanish.

4.2. Debriefing Interview

The final test instrument, used to elicit overt attitudes towards /l/ production, intervocalic /s/ production, and Catalanian Spanish overall, was a debriefing interview of approximately 10 minutes conducted by the investigator using an H4N Zoom microphone after completion of the matched guise. Participants were asked to articulate any strategies they used to justify their responses on the matched guise (for example, ‘Did you think any of the voices you heard came from a speaker of Catalan? How could you tell?’), discuss features or characteristics of Catalan-accented Spanish of which they are aware (for example, ‘What does the Spanish of a Catalan speaker sound like? Can you think of any obvious features of their accent that give it away?’), and elaborate on the status of Catalanian Spanish (for example, ‘How would you react if someone told you that they could tell you spoke Catalan based on your Spanish?’ Do you think you speak Spanish with a Catalan accent? Do you think it’s ok to speak Spanish with a Catalan accent within Catalonia? What about outside of Catalonia?). In total, these experimental tasks took approximately 35 minutes to complete, per participant.

4.3. Subject Population

The total of 54 participants were recruited in 2012 in two principal testing sites, namely Barcelona and Madrid, mirroring Sinner (2002). The former was divided into three groups based on profiles of language dominance and a city/village divide, whereas the latter served as a smaller control group that permitted a comparison of attitudes of the Catalan-Spanish community with those of an outsider monolingual Spanish community. Bilingual participants were classified into listener groups based on reported usage of Catalan and Spanish in their daily lives and familial upbringing, though notably, as generalized bilingualism is a widespread feature of Catalonian society, all bilingual speakers tested display a fully functional command of both languages. Though all Barcelona participants are from the Barcelona Metropolitan Area (BMA), those from the urban capital (population = 1,573,318 [Institut d'Estadística de Catalunya, 2011]) are contrasted with those from smaller, Catalan-prevalent villages (average population = 7,419 [Institut d'Estadística de Catalunya, 2011]) on the outskirts of the BMA, capturing potential differences in attitudes reflecting the urban/rural divide noted in Sinner (2002). All speakers were recruited as paid participants via flyer advertisements displayed in each testing location, and had minimally completed secondary education. Table 1, below, visualizes the four profiles of listeners, displaying relevant descriptive statistics for each group (note that listener gender was equally balanced across all groups, and the limitation of a smaller sample size for the control group of Madrid monolinguals).

Table 1: Subject Population and Listener Profile Groups

Listener Group	Participant Count (Mean Age)	Home Language / Native Language / Parent Native Language	Daily Spanish Use	2013 Linguistic Census Data for City-Wide Catalan Competencies (Understand / Speak / Read / Write)*
A – Catalan-dominant, Village (bilingual)	16 (25; SD = 8.5)	Catalan	7% (SD = 5.8)	98% / 88% / 88% / 70%
B – Catalan-dominant, City (bilingual)	16 (23; SD = 9.8)	Catalan	10% (SD = 6.9)	95% / 72% / 79% / 53%
C – Spanish-dominant, City (bilingual)	16 (26; SD = 9.2)	Spanish	77% (SD = 10.8)	
D – Madrid (monolingual)	6 (23; SD = 5.1)	Spanish	100% (SD = 0)	N/A

*Source: Institut d'Estadística de Catalunya, 2014

5. Data Analysis Methods and Results

5.1. Data Analysis

Covert attitudes towards /l/ production and intervocalic /s/ production were elicited using the matched guise, whereas overt attitudes towards these phenomena and Catalonian Spanish overall were elicited in the debriefing interview. Since the former utilized Likert and semantic-differential scales, these quantitative data were normalized by converting individual responses into z-scores, combining responses across items that pertained to the same attitudinal category. In contrast, interview data were analyzed qualitatively, though select counts (such as the number of participants that identified either [h] or intervocalic [z] as a feature of Catalonian Spanish) were calculated and assessed using a proportion analysis.

5.2. Matched Guise Results (Covert Attitudes)

Normalized (z-score) matched guise responses for each of the five attitudinal categories (solidarity, power, accent, rurality, bilingualism) were assessed individually for each of the target guise pairs (e.g. laterals and fricatives). For each of these analyses, we employed a pair of mixed-effects linear regression in R (R Core Team 2018) using each attitudinal category score as the dependent variable (i.e., one model using responses for the lateral guises and one model using responses for the fricative guises). Independent variables (i.e., guise type and listener profile group) remained constant,

whereby we tested for a main effect of the particular guise in question (for lateral models, [ʔ] vs. [l], and for fricative models, [z] vs. [s]) and an interaction effect between guise and listener profile group (group A vs. B vs. C vs. D) in order to verify if a significant difference in attitudinal score between the guises was consistent both in presence and/or magnitude across the four listener groups.⁷ Additionally, individual listener was incorporated as a random effect. Note that all subsequent figures visualizing the reported results, for ease of interpretation, use raw responses on the aforementioned 1-7 scale. Moreover, in all subsequent figures, listener groups will appear combined when they exhibit, in parallel, either a statistically significant effect of equal magnitude and direction, or a lack of statistically significant effect. Accordingly, separate visualizations of scores for listener profile groups reflect a statistically significant difference with respect to the presence of absence of an effect, the magnitude of an effect, and/or the direction of an effect, across these groups.

5.2.1. Solidarity Scores

With respect to evaluations of solidarity for the lateral guises, the results of the aforementioned linear mixed-effects regression appear below in table 2 (note that negative β coefficients indicate lower solidarity ratings [i.e., less nice, less pleasant, less friendly] compared to the intercept). The ANOVA table generated from the mixed-effects model returned a significant main effect of guise ($F[1,50] = 99.37, p < .0001$) and a significant interaction between guise and listener profile group ($F[3,50] = 66.98, p < .0001$).

Table 2 - Summary of Mixed-Effects Linear Regression Model Fitted to /l/ Solidarity Scores

	β	t	p
(Intercept)*	0.8954	6.349	<.0001
Group B	-0.2012	-1.009	0.3165
Group C	-.05263	-2.638	0.0102
Group D	-2.3836	-8.826	<.0001
Light Guise	-1.2073	-9.968	<.0001
Group B : Light Guise	-0.1238	-0.723	0.4731
Group C : Light Guise	0.2786	1.627	0.1101
Group D : Light Guise	2.9821	12.859	<.0001

*The intercept is Group A listeners rating the dark guise.
The estimated variance of the random effect of listener is 0.2009.

Post-hoc analyses for the significant interaction effect (with Bonferroni correction [α level = 0.0125]) revealed that all three bilingual groups (A, B, and C) attributed equally significantly higher solidarity scores to the dark guise over the light guise (for all, $p < .0001$), whereas the Madrid listeners (D) uniquely afforded significantly higher solidarity scores to the light guise over the dark guise ($p < .0001$). These findings are visualized below in figure 4.

Figure 4 - Solidarity Score Differences for Light and Dark /l/ Guises

⁷ The only statistical comparisons of relevance to our research questions are those concerned with whether or not each group of listeners differentiated each of the target guises ([ʔ] vs. [l], and [z] vs. [s]) by attitudinal category, namely a main effect of guise and/or an interaction effect between guise and listener profile group. Accordingly, we limit our reporting and discussion of results to these two effects. Any potential main effect of listener profile group would reflect non-substantive comparisons of averaged lateral ratings or averaged fricative ratings by group (i.e., there is no meaningful interpretation of the average solidarity rating for /l/ or /s/, rather, it is the possible difference in evaluation between [ʔ] and [l] or [z] and [s] that is of consequence).

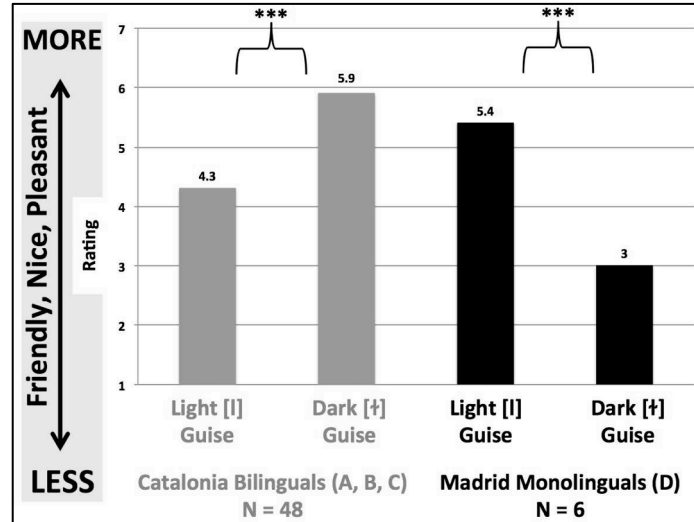

With respect to evaluations of solidarity for the fricative guises, the results of the aforementioned linear mixed-effects regression appear below in table 3 (recall that negative β coefficients indicate lower solidarity ratings [i.e., less nice, less pleasant, less friendly] compared to the intercept). The ANOVA table generated from the mixed-effects model returned a significant main effect of guise ($F[1,50] = 78.41, p < .0001$) and a significant interaction between guise and listener profile group ($F[3,50] = 12.44, p < .0001$).

Table 3 - Summary of Mixed-Effects Linear Regression Model Fitted to Intervocalic /s/ Solidarity Scores

	β	t	p
(Intercept)*	0.72252	4.686	<.0001
Group B	-0.14136	-0.648	0.51885
Group C	0.25131	1.153	0.25291
Group D	-0.93195	-3.156	0.00233
Voiceless Guise	-1.19373	-8.855	<.0001
Group B : Voiceless Guise	-0.01571	-0.082	0.93467
Group C : Voiceless Guise	-0.14136	-0.741	0.46188
Group D : Voiceless Guise	1.36128	5.273	<.0001

*The intercept is group A listeners rating the voiced guise.
The estimated variance of the random effect of listener is 0.235.

Post-hoc analyses of the significant interaction effect (with Bonferroni correction [alpha level = 0.0125]) revealed that all three bilingual groups (A, B, and C) attributed equally significantly higher solidarity scores to the voiced guise over the voiceless guise (for all, $p < .0001$), whereas the Madrid listeners uniquely rated the two guises equally ($p = .45$). These findings are visualized below in figure 5.

Figure 5 - Solidarity Score Differences for Voiceless and Voiced /s/ Guises

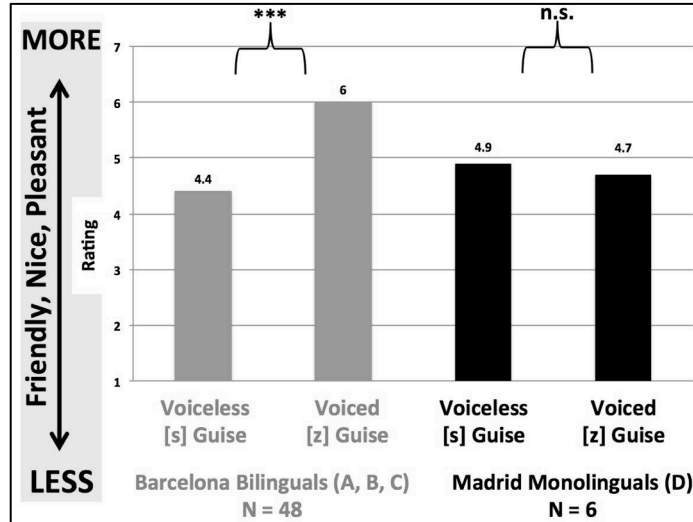

5.2.2. Power Scores

With respect to evaluations of power for the lateral guises, the results of the aforementioned linear mixed-effects regression appear below in table 4 (note that negative β coefficients indicate lower power ratings [i.e., less educated, less likely to have a high-paying job, less trustworthy] compared to the intercept). The ANOVA table generated from the mixed-effects model returned no significant effect of guise ($F[1,50] = 0.35, p=.56$) and there was no significant interaction between guise and listener profile group ($F[3,50] = 0.15, p=.93$). As visualized below in figure 6, no listener group differentially evaluates Barcelonan Spanish laterals with respect to power.

Table 4 - Summary of Mixed-Effects Linear Regression Model Fitted to /l/ Power Scores

	β	t	p
(Intercept)*	-.4662	-3.053	0.00349
Group B	0.0986	0.458	0.64863
Group C	-0.03959	-0.183	0.85526
Group D	0.05278	0.18	0.85744
Light Guise	0.03959	0.591	0.55709
Group B : Light Guise	-0.00001	0	1
Group C : Light Guise	-0.01979	-0.209	0.8353
Group D : Light Guise	0.06598	0.515	0.60915

*The intercept is group A listeners rating the dark guise.
The estimated variance of the random effect of listener is 0.33734.

Figure 6 - Power Score Differences for Light and Dark /l/ Guises

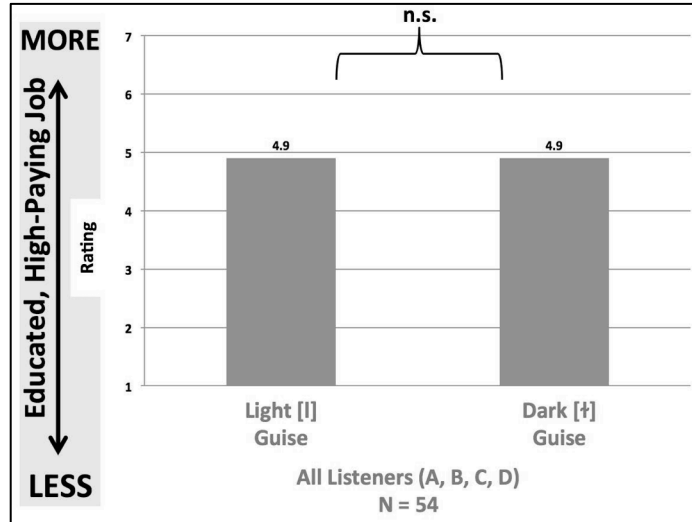

With respect to evaluations of power for the fricative guises, the results of the aforementioned linear mixed-effects regression appear below in table 5 (recall that negative β coefficients indicate lower power ratings [i.e., less educated, less likely to have a high-paying job, less trustworthy] compared to the intercept). The ANOVA table generated from the mixed-effects model returned no significant effect of guise ($F[1,50] = 0.18, p=.67$) and there was no significant interaction between guise and listener profile group ($F[3,50] = 0.68, p=.57$). Accordingly, no listener group differentially evaluates Barcelonan Spanish fricatives with respect to power, as visualized below in figure 7.

Table 5 - Summary of Mixed-Effects Linear Regression Model Fitted to Intervocalic /s/ Power Scores

	β	t	p
(Intercept)*	-0.30877	-2.067	0.04323
Group B	0.05299	0.251	0.80287
Group C	0.63585	3.009	0.00386
Group D	0.73005	2.552	0.01336
Voiceless Guise	0.03532	0.427	0.67151
Group B : Voiceless Guise	0.10597	0.905	0.36983
Group C : Voiceless Guise	-0.05299	-0.452	0.65289
Group D : Voiceless Guise	-0.03532	-0.223	0.82461

*The intercept is group A listeners rating the voiced guise.
The estimated variance of the random effect of listener is 0.30231.

Figure 7 - Power Score Differences for Voiceless and Voiced /s/ Guises

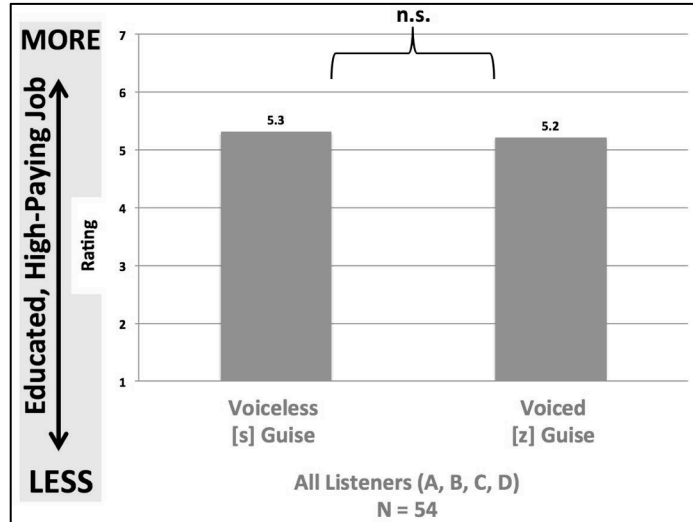

5.2.3. Accent Scores

With respect to evaluations of accent for the lateral guises, the results of the aforementioned linear mixed-effects regression appear below in table 6 (note that negative β coefficients indicate lower accent ratings [i.e., spoke Spanish less well, had a less pretty accent] compared to the intercept). The ANOVA table generated from the mixed-effects model returned a significant main effect of guise ($F[1,50] = 126.87, p < .0001$), such that more positive accent ratings (i.e., prettier accent, better spoken Spanish) were attributed to the light guise over the dark guise. As no significant effect was found for the interaction between guise and listener profile group ($F[3,50] = 2.52, p = .07$), this differential evaluation of laterals was uniform across all listener groups, visualized below in figure 8.

Table 6 - Summary of Mixed-Effects Linear Regression Model Fitted to /l/ Accent Scores

	β	t	p
(Intercept)*	-0.66484	-4.562	<.0001
Group B	0.22415	1.088	0.2805
Group C	-0.05604	-0.272	0.7865
Group D	0.13076	0.469	0.6409
Light Guise	1.34491	11.264	<.0001
Group B : Light Guise	-0.02154	-0.152	0.7553
Group C : Light Guise	-0.01868	-0.111	0.9124
Group D : Light Guise	-0.14943	-0.654	0.5164

*The intercept is group A listeners rating the dark guise.
The estimated variance of the random effect of listener is 0.2258.

Figure 8 - Accent Score Differences for Light and Dark /l/ Guises

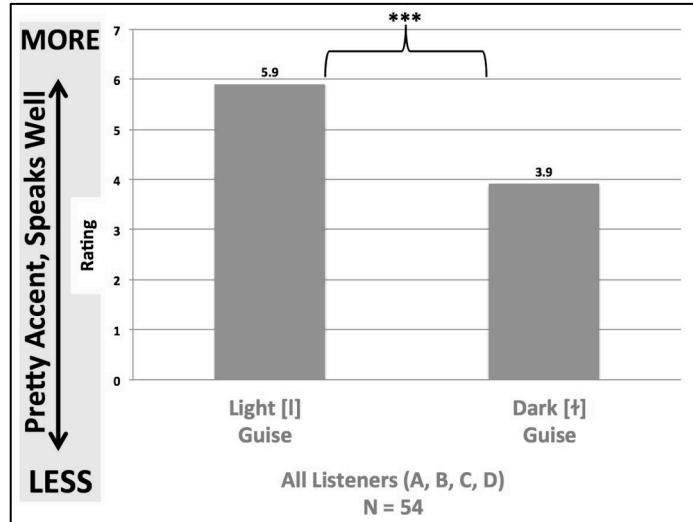

With respect to evaluations of accent for the fricative guises, the results of the aforementioned linear mixed-effects regression appear below in table 7 (note that negative β coefficients indicate lower accent ratings [i.e., spoke Spanish less well, had a less pretty accent] compared to the intercept). The ANOVA table generated from the mixed-effects model returned no significant effect of guise ($F[1,50] = 0.61, p=.44$) and there was no significant interaction between guise and listener profile group ($F[3,50] = 0.75, p=.53$). Accordingly, no listener group differentially evaluates Barcelonan Spanish fricatives with respect to accent, as visualized below in figure 9.

Table 7 - Summary of Mixed-Effects Linear Regression Model Fitted to Intervocalic /s/ Accent Scores

	β	t	p
(Intercept)*	-0.40144	-2.284	0.026
Group B	0.36618	1.473	0.1461
Group C	0.6103	2.456	0.0171
Group D	0.84628	2.515	0.0147
Voiceless Guise	-0.07324	-0.778	0.4401
Group B : Voiceless Guise	0.17088	1.284	0.2051
Group C : Voiceless Guise	.017088	1.284	0.2051
Group D : Voiceless Guise	0.07324	0.406	0.6862

*The intercept is group A listeners rating the voiced guise.
The estimated variance of the random effect of listener is 0.42323.

Figure 9 - Accent Score Differences for Voiceless and Voiced /s/ Guises

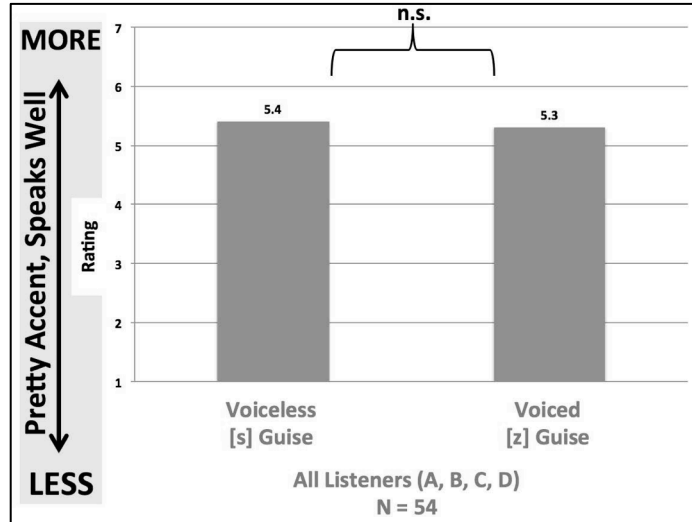

5.2.4. Rurality Scores

With respect to evaluations of rurality for the lateral guises, the results of the aforementioned linear mixed-effects regression appear below in table 8 (note that negative β coefficients indicate higher rurality ratings [i.e., more likely to be from a village] compared to the intercept). The ANOVA table generated from the mixed-effects model returned a significant main effect of guise ($F[1,50] = 150.72, p < .0001$) and a significant interaction between guise and listener profile group ($F[3,50] = 6.23, p = .001$).

Table 8 - Summary of Mixed-Effects Linear Regression Model Fitted to /l/ Rurality Scores

	β	t	p
(Intercept)*	-1.3294	-9.546	<.0001
Group B	0.4341	2.204	0.0302
Group C	0.9015	4.577	<.0001
Group D	1.7251	6.469	<.0001
Light Guise	1.8698	12.277	<.0001
Group B : Light Guise	-0.3673	-1.705	0.0944
Group C : Light Guise	-0.4675	-2.17	0.0348
Group D : Light Guise	-1.2465	-4.274	<.0001

*The intercept is group A listeners rating the dark guise.
The estimated variance of the random effect of listener is 0.1247.

Post-hoc analyses of the significant interaction effect (with Bonferroni correction [alpha level = 0.0125]) revealed that all three bilingual groups (A, B, and C) attributed equally significantly higher rurality scores (i.e., less likely to be from the city) to the dark guise over the light guise (for all, $p < .0001$). This effect, while in the same direction for the Madrid listeners, failed to achieve statistical significance ($p = .015$). These findings suggest that dark laterals index speaker rurality or non-urban background within the Catalan-Spanish community, whereas for Madrid listeners, this association is either wholly absent or considerably weaker. These results are visualized below in figure 10.

Figure 10 - Rurality Score Differences for Light and Dark /l/ Guises

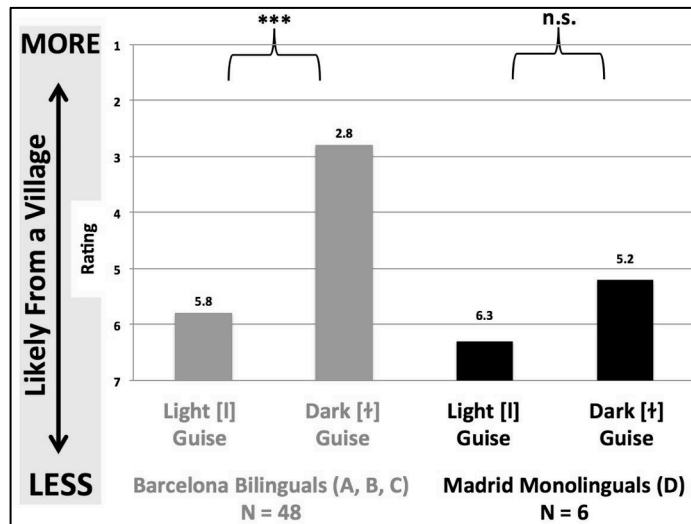

With respect to evaluations of accent for the fricative guises, the results of the aforementioned linear mixed-effects regression appear below in table 9 (note that negative β coefficients indicate higher rurality ratings [i.e., more likely to be from a village] compared to the intercept). The ANOVA table generated from the mixed-effects model returned no significant effect of guise ($F[1,50] = 1.01, p=.32$) and there was no significant interaction between guise and listener profile group ($F[3,50] = 0.28, p=.84$). Accordingly, no listener group differentially evaluates Barcelonan Spanish fricatives with respect to rurality, as visualized below in figure 11.

Table 9 - Summary of Mixed-Effects Linear Regression Model Fitted to Intervocalic /s/ Rurality Scores

	β	t	p
(Intercept)*	-0.5779	-2.373	0.0212
Group B	0.7673	2.228	0.03
Group C	0.8185	2.377	0.021
Group D	0.6309	1.353	0.1816
Voiceless Guise	0.1023	1.007	0.3189
Group B : Voiceless Guise	-0.1023	-0.712	0.4799
Group C : Voiceless Guise	-0.00001	0	1
Group D : Voiceless Guise	0.0341	0.175	0.8616

*The intercept is group A listeners rating the voiced guise.
The estimated variance of the random effect of listeners is 0.86587.

Figure 11 - Rurality Score Differences for Voiceless and Voiced /s/ Guises

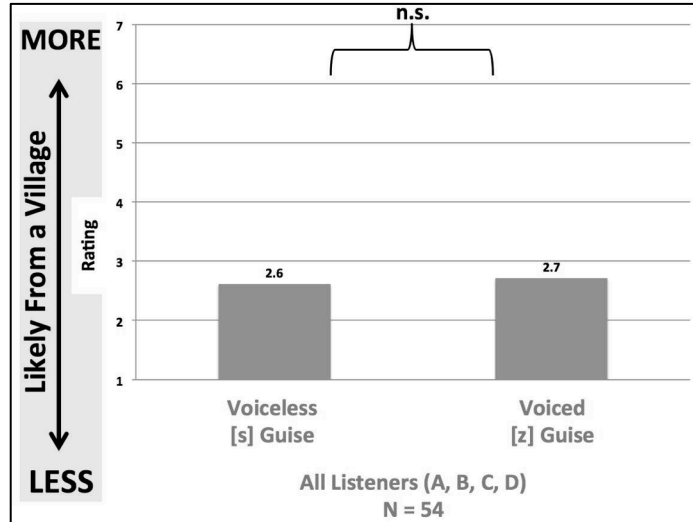

5.2.5. Bilingualism Scores

With respect to evaluations of bilingualism for the lateral guises, the results of the aforementioned linear mixed-effects regression appear below in table 10 (note that negative β coefficients indicate lower accent ratings [i.e., less likely to be a Catalan speaker] compared to the intercept). The ANOVA table generated from the mixed-effects model returned a significant main effect of guise ($F[1,50] = 20.54, p < .0001$), such that higher bilingualism ratings (i.e., more likely to be a Catalan speaker) were attributed to the dark guise over the light guise. As no significant effect was found for the interaction between guise and listener profile group ($F[3,50] = 1.17, p = .33$), this differential evaluation of laterals was uniform across all listener groups, visualized below in figure 12.

Table 10 - Summary of Mixed-Effects Linear Regression Model Fitted to /l/ Bilingualism Scores

	β	t	p
(Intercept)*	0.71267	3.606	0.000488
Group B	-0.07127	-0.255	0.799277
Group C	-0.2138	-0.765	0.446143
Group D	-0.09502	-0.251	0.802277
Light Guise	-1.24718	-4.532	<.0001
Group B : Light Guise	0.1069	0.275	0.784689
Group C : Light Guise	0.2138	0.549	0.585195
Group D : Light Guise	-0.74831	-1.42	0.161788

*The intercept is group A listeners rating the dark guise.
The estimated variance of the random effect of listener is 0.01923.

Figure 12 - Bilingualism Score Differences for Light and Dark /l/ Guises

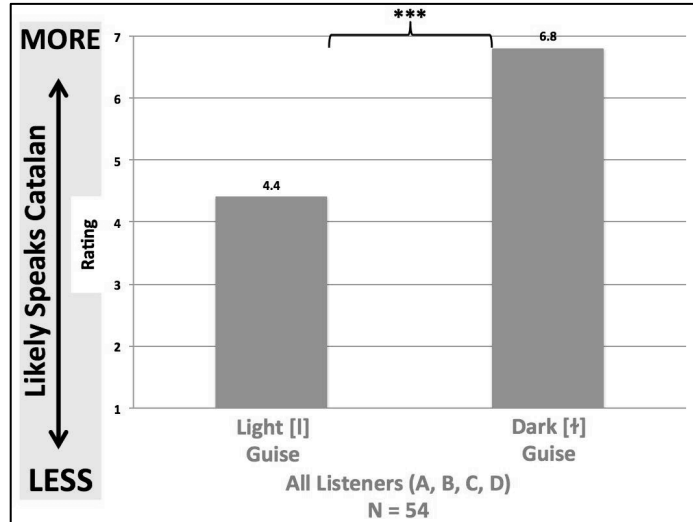

With respect to evaluations of bilingualism for the fricative guises, the results of the aforementioned linear mixed-effects regression appear below in table 11 (note that negative β coefficients indicate lower accent ratings [i.e., less likely to be a Catalan speaker] compared to the intercept). The ANOVA table generated from the mixed-effects model returned a significant main effect of guise ($F[1,50] = 18.57, p < .0001$) and a significant interaction between guise and listener profile group ($F[3,50] = 4.43, p = .008$).

Table 11 - Summary of Mixed-Effects Linear Regression Model Fitted to Intervocalic /s/ Bilingualism Scores

	β	t	p
(Intercept)*	0.8698	4.174	<.0001
Group B	-0.3753	-1.273	0.2069
Group C	-0.5316	-1.804	0.0753
Group D	-1.6574	-4.154	<.0001
Voiceless Guise	-0.8131	-4.309	<.0001
Group B : Voiceless Guise	-0.5003	-1.875	0.0666
Group C : Voiceless Guise	0.1564	0.586	0.5605
Group D : Voiceless Guise	0.7297	2.02	0.0488

*The intercept is group A listeners rating the voiced guise.
The estimated variance of the random effect of listener is 0.4099.

Post-hoc analyses of the significant interaction effect (with Bonferroni correction [alpha level = 0.0125]) revealed that all three bilingual groups (A, B, and C) attributed equally significantly higher bilingualism scores to the voiced guise over the voiceless guise (for A and B, $p < .0001$; for C, $p = .001$), whereas the Madrid listeners uniquely rated the two guises equally ($p = .788$). These findings are visualized below in figure 13.

Figure 13 - Bilingualism Score Differences for Voiceless and Voiced /s/ Guises

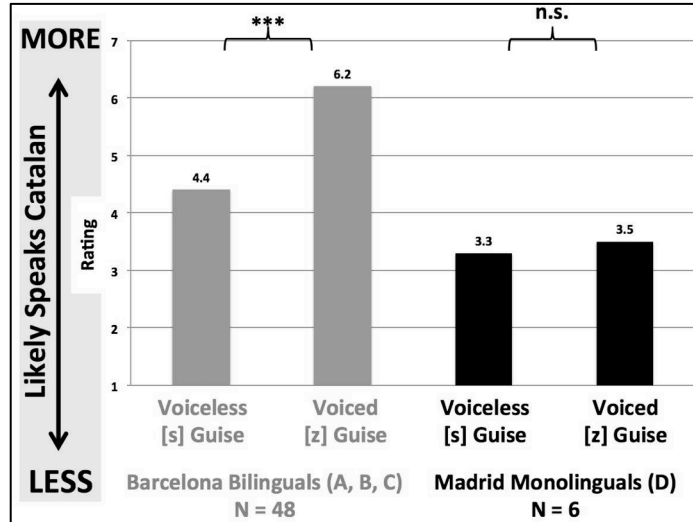

5.3. Debriefing Interview Results (Overt Attitudes)

In order to assess the relative salience of /l/ and intervocalic /s/ as recognized features of Catalan Spanish, listeners (the majority of which hail from Barcelona) were asked to explicitly name all phonetic features of Catalan Spanish of which they were aware. A total of five Catalan Spanish features⁸ were named, and the frequencies with which each was mentioned were analyzed as proportions and submitted to a Chi-square test. The results, shown below in table 12 and figure 14, reveal that the proportion of overt awareness was not equally distributed across the named features ($\chi^2=63.555$, $df=4$, $p<.0001$ [with Yates' correction]). Post-hoc cell-wise comparisons (for each, $p<.001$) revealed that the proportion of awareness was equally significantly higher for velarized [ɫ] and non-standard vowels and equally significantly lower for the lack of /θ/ and intervocalic /s/-voicing.

Table 12 - Counts of Explicit Awareness for Phonetic Features of CCS

	Velarized [ɫ]	Vowels ([ə], [ɛ], [ɔ])	Devoiced Final Stops	Lack of /θ/	Intervocalic /s/-voicing	TOTAL
Named Feature	35	32	13	7	4	91
Did Not Name Feature	19	22	41	47	50	179
TOTAL	54	54	54	54	54	270

Figure 14 - Percentages of Awareness for Phonetic Features of Catalan Spanish

⁸ In addition to [ɫ] and intervocalic [z], additional features were the use of Catalan-like vowels (i.e., the central vowel [ə] in words like *vaca* 'cow' [bá.kə] vs. standard Castilian [bá.ka]), devoiced final stops (i.e., the application of a Catalan phonotactic devoicing rule in Spanish that realizes word-final /d/ as [t̚] in words like *amistad* 'friendship' [a.mis.t̚á.t̚] vs. standard Castilian [a.mis.t̚á.d̚]), and the absence of the interdental voiceless fricative phoneme /θ/, foreign to Catalan, in words like *zapato* 'shoe' [sa.pá.t̚o] vs. standard Castilian [θa.pá.t̚o]).

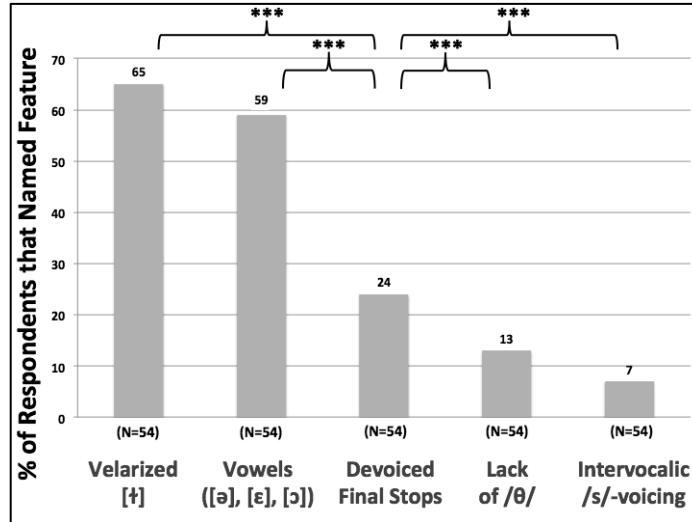

Given the widespread (~65%) awareness of [ɫ] as a hallmark feature of Catalans' Spanish, it is unsurprising that the majority of participants were readily able to offer explicit commentary concerning their attitudes toward *la ele catalana* 'the Catalan /l/'. While the predominant commentary involved an explicit understanding of Spanish [ɫ] as poor Spanish and warranting correction, Catalan-dominant bilinguals (listener groups A and B) discussed this social expectation in terms of their own violation of it, whereas Spanish-dominant bilinguals (listener group C) framed it in terms of their successful ability to adhere to it:

- (1) "Bueno, la ele catalana, sí... yo intento no usarla cuando hablo castellano, porque quiero hablarlo bien, pero bueno, me sale como me sale [Well, the Catalan /l/, yes... I try not to use it when I speak Spanish, because I want to speak it well, but well, it comes out how it comes out]" (Subject 12, Group A);
- (2) "Mira, supuestamente las eles no las debemos hacer tan catalanas, pero soy catalán y hablo catalán, entonces claro que voy a tener algunos dejes así cuando hablo en castellano, es inevitable [Look, supposedly we shouldn't make the /l/s so Catalan-like, but I'm Catalan and I speak Catalan, so of course I'm going to have some accent features like this when I speak in Spanish, it's inevitable]" (Subject 19, Group B);
- (3) "No no, yo no uso la ele catalana cuando hablo castellano. Hablo correctamente y cuando hablo en castellano, uso la ele castellana, y en catalán, pues sólo allí la catalana. [No no, I don't use the Catalan /l/ when I speak Spanish. I speak correctly and when I speak in Spanish, I use the Spanish /l/, and in Catalan, well only then the Catalan /l/]" (Subject 42, Group C).

In spite of the recognition of prescriptive norms precluding [ɫ] from 'correct' or 'proper' Spanish, an equally common notion expressed across all listener groups, bilingual and monolingual alike, was one of ambivalence or neutral acceptance of the *ele catalana* as a somewhat natural and inconsequential product of bilingualism:

- (4) "Si hago las eles muy catalanas, ¿qué más da? Todos aquí hablamos así, es normal [If I make my /l/s very Catalan-like, what does it matter? Everybody here speaks like this, it's normal]" (Subject 5, Group A);
- (5) "La ele catalana, las vocales catalanas, mira - mucho deje puedes tener en tu castellano, pero tampoco no importa mucho, se entiende igual, ¿sabes? [The Catalan /l/, Catalan vowels, look - you can have a lot of Catalan accent in your Spanish, but it doesn't matter much, it's understandable just the same, you know?]" (Subject 20, Group B);
- (6) "Yo no creo que haga las eles así, muy catalanas, pero... no sé, si las hiciera muy catalanas, no importaría mucho. No sé, está bien, no pasa nada [I don't think I do the /l/s this way, very Catalan-like, but... I don't know, if I did them very Catalan-like, it wouldn't matter much. I don't know, it's ok, it doesn't matter]" (Subject 44, Group C);
- (7) "No es nada malo, de hecho lo veo bastante natural. Si hablan el catalán como primera lengua, obviamente van a tener la ele catalana en su castellano [It's nothing bad, in fact I see it as rather

natural. If they speak Catalan as a first language, obviously they're going to have the Catalan /l/ in their Spanish]" (Subject 51, Group D).

As for attitudes towards the use of intervocalic [z] in Catalan Spanish, given its relative scarcity of overt awareness (~7%) as a feature of Catalan Spanish, no explicit commentary towards [z] was offered. Unlike [H], whose notoriety is captured in its renowned label as *la ele catalana* for Catalan listeners and Madrid listeners alike, no parallel term (as could be, for example, *la ese catalana* 'the Catalan /s/') was employed by the few listeners that were aware of [z], who instead referred to it by using the sound in an example phrase like *lo[z] amigos* 'the friends.' The lack of overt awareness of intervocalic [z] is perhaps best exemplified by one particular group A listener, who after being explicitly prompted to hypothesize about some possible 'Catalanized' way of pronouncing the phrase *mis amigos* 'my friends,' repeated *mis amigos* aloud to herself using [z], and ironically still could not identify [z] as a trait of Catalan Spanish. Figure 15 below shows the spectral analysis of the word-final prevocalic /s/ in *mis amigos* as the participant was thinking aloud:

- (8) " 'Mis amigos' ... No sé, es que como yo siempre me oigo a mí, bueno, sabes... no... no lo sé ['My friends'... I don't know, it's that since I always hear myself, well, you know... no... I don't know]" (Subject 11, Group A).

Figure 15 – Explicit rendition of *mis amigos* 'my friends' (100% voiced /s/)

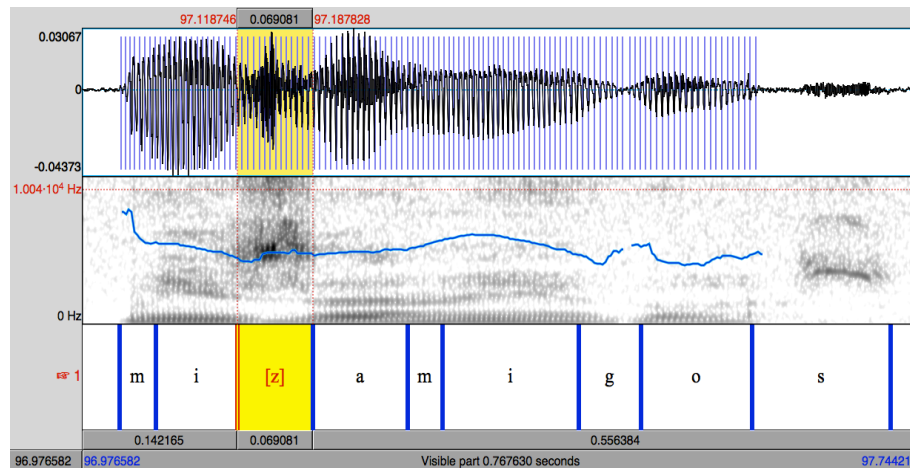

With respect to attitudes on 'Catalanized' Spanish in general, commentary was commonly positive (i.e., favorable opinions toward the variety) amongst bilingual groups, while somewhat ambivalent for the Madrid speakers. A frequent explanation for why bilinguals felt an affinity toward Catalan-accented Spanish was because it reminded them of the Catalan language and of Catalan speakers. However, within the commentaries of Catalan-dominant speakers, negative commentary involving social ridicule appeared frequently, specifically with respect to an overly 'Catalanized' accent:

- (9) "Buena, sí, me gusta. Me da un poco de envidia porque se nota que es una persona que habla bien el catalán, y yo no considero que hablo muy bien el catalán... pero sí, entre la gente de aquí, está bien visto [Well, yes, I like it. It makes me a little jealous because you can tell it's someone that speaks Catalan well, and I don't believe I speak Catalan very well... but yes, amongst the people from here, it's viewed favorably]" (Subject 38, Group C);
- (10) "Pienso que es de mi país, que es catalán, que es como yo. Claro, es como simpatía, es como patriota. Como persona, me transmite cosas positivas, más que un andaluz, por ejemplo... pero no me gusta que la gente se ría de mi acento súper-catalán [I think that s/he is from my country, that s/he is Catalan, that s/he is like me. Of course, it's like sympathy, it's like a patriot. As a person, s/he transmits positive things to me, more than an Andalusian, for example... but I don't like that people laugh at my super-Catalan accent]" (Subject 26, Group B);
- (11) "No está mal, es un acento más, es como los andaluces, ¿no? Tienen su acento... pues lo mismo con nosotros, ¿no? Claro, intento que no sea tan exagerado, pero me cuesta. Porque mucha gente, cuando hablo castellano, me lo ha dicho, que tengo mucho acento de catalán, entonces intento que

- no se note tanto* [It's not bad, it's one accent more, it's like the Andalusians, no? They have their accent... well the same with us, no? Of course, I try to make it not so exaggerated, but it's hard for me. Because a lot of people, when I speak Spanish, have told me so, that I have a strong Catalan accent, so I try to make it so it's not as noticeable]" (Subject 15, Group C);
- (12) *"No está mal, simplemente es otro castellano. O sea cada región tiene su acento, ¿no? Aquí en Madrid tenemos nuestro acento, pues allí en Cataluña tienen el suyo, igual que en Andalucía el suyo. No es cuestión de mejor o peor, sino acentos diferentes. Todos son la misma lengua* [It's not bad, it's simply another Spanish. In other words every region has its accent, no? Here in Madrid we have our accent, so there in Catalonia they have theirs, just like in Andalusia theirs. It's not a matter of better or worse, but rather different accents. They're all the same language]" (Subject 50, Group D).

6. Discussion

The matched guise and debriefing interview respectively elicited covert and overt attitudes concerning /l/ and intervocalic /s/ production in Catalan Spanish. Five main attitudinal categories were considered, namely solidarity, power, accent, rurality, and bilingualism, all of which save power were found to be associated with one or both phenomena. Solidarity judgments, for each of /l/ and /s/ production, were differential across bilingual (Barcelona) and monolingual (Madrid) listeners. The bilingual listeners afforded higher solidarity to the Catalan Spanish variants ([ɫ] and [z]), whereas Madrid listeners rated standard Spanish [l] higher than [ɫ], and did not evaluate fricative variants distinctly. These increased solidarity judgments for Catalan Spanish variants on the part of Catalan listeners demonstrate a certain affinity toward [ɫ] and [z] that likely relates to their association with Catalan identity and prominent use in the Spanish of Catalonia, since Catalan listeners also covertly linked each of these variants to Catalan-Spanish bilingualism. Madrid listeners, on the other hand, only associated [ɫ] with Catalan-Spanish bilingualism. Overt attitudes corroborate these covert judgments inasmuch as the majority of (all) listeners explicitly described *la ele catalana* as a plainly recognizable feature of Catalans' Spanish, mirroring the results reported in Sinner (2002), who also found that [ɫ] was the only phonetic feature of Catalan-accented Spanish overtly recognized by speakers within and outside of the Catalan-speaking community. The relative lack of overt awareness of [z], particularly amongst Catalan listeners that covertly afforded [z] high solidarity and bilingualism scores, combined with prior production evidence showing a robust usage of [z] by Catalan-Spanish bilinguals and in particular those with greatest exposure to and usage of Catalan (Davidson, 2014, p. 233-235; 2015, p. 132-134), suggests that [z] likely functions as a sociolinguistic indicator (cf. Labov, 2001) of Catalan Spanish within the Catalan speech community, indexing Catalan-Spanish bilingual membership while lacking any considerable degree of generalized conscious awareness.

Judgments of accent and rurality regarding [ɫ] reveal additional nuances of the social status of lateral velarization in Catalan Spanish. Covert associations of [ɫ] with incorrect and/or non-pretty-sounding Spanish were found for all listeners, whereas additional links to increased perception of rurality for [ɫ] were only found for bilingual listeners. Intervocalic /s/ voicing, in contrast, was not covertly associated with accent nor rurality for any listener group.⁹ Accordingly, explicit commentary regarding speaking 'good' Spanish appeared most often with respect to the prescriptive avoidance of [ɫ] with Catalan-dominant speakers acknowledging, as if defeatedly, their futility of avoiding [ɫ] in Spanish, and Spanish-dominant speakers conversely claiming a sense of accomplishment in their capacity to restrict [ɫ] to Catalan (see [1], [2], and [3] in section 5.3). This sense of linguistic purism, namely the notion that 'proper' Spanish shows no signs of contact influence from another language, can relegate contact phenomena such as the present case of Spanish dark [ɫ] to a position of inferiority and potentially even outright disdain within and outside of the bilingual speech community, as

⁹ Following Barnes (2015, p. 232-233), the greater degree of social indexation afforded to lateral production over fricative production, as manifested in the former's greater number of covert associations with attitudinal categories and overt links to prescriptive norms of standard Spanish, suggests that laterals are more 'sociolinguistically salient' than alveolar fricatives in Catalan Spanish. As listeners also demonstrated more overt awareness of differences in laterals than in fricatives, it is likely that laterals are also more phonetically or acoustically salient than fricatives as well, which logically would contribute to the former's greater propensity for social indexation.

evidenced by bilingual listeners' anecdotes of being made fun of for speaking Spanish with too strong of a Catalan accent. It would seem most probable that Spanish [ɫ] exists as a linguistic stereotype (cf. Labov, 2001) of the Catalan-Spanish community, indexing membership in this bilingual community while being the subject of overt, negative commentary and to a degree being expressly suppressed (though not necessary successfully) in the Spanish of Catalan speakers in an effort to speak, in their opinion, 'better' Spanish. Additionally, though collected in a different Catalan-Spanish community, the present attitudinal findings provide corroboration for the production trends noted for dark [ɫ] in Majorcan Spanish (cf. Pieras, 1999; Simonet, 2010a; 2010b), for which the active avoidance of darker laterals on behalf of youth female speakers was interpreted as part of a change from above (cf. Labov, 2001) motivated by the negative social value afforded to dark laterals.

Though Sinner's (2002) interviews with Barcelona and Madrid speakers took place well over a decade ago, their overt commentary concerning [ɫ] and Catalanian Spanish as generally unpleasant, flawed, and/or country-like in comparison to the Peninsular standard norm, was, to a degree, faithfully corroborated in the present study in the form of both covert attitudes (i.e., matched guise scores for accent and rurality attributes for [ɫ]) and overt attitudes (i.e., interview commentary about desires to limit individual use of Spanish [ɫ] and heavily Catalan-accented Spanish). These results furthermore echo those of matched guise studies carried out in Barcelona in the late 20th century (cf. Woolard, 1984; 1989; Woolard & Gahng, 1990) that found L2-accented Spanish and Catalan to be dispreferred over more native-sounding speech. However, the present study additionally uncovered both covert and overt positive esteem toward Catalanian Spanish and indeed even dark [ɫ] inasmuch as solidarity attributes were concerned, in line with what Newman (2011), Newman et al. (2008), and Trenchs-Parera & Newman (2009) proclaim as an emerging shift in the linguistic ideologies of Catalonia toward linguistic cosmopolitanism, or the erosion of a prior in-group/out-group opposition between native speakers and non-native speakers, replaced by one between bilingual speakers and monolingual (Spanish) speakers.

Ultimately, we are left with somewhat of an ideological paradox when it comes to Catalanian Spanish and its more sociolinguistically salient features (e.g. [ɫ]), in that listeners simultaneously project positive esteem, via solidarity attributes, alongside negative stigma, principally via accent attributes. This paradox, reminiscent of Ryan's (1979, as cited in Labov, 2001, p. 263) conjecture, "why do low-prestige language varieties persist?", highlights the conflict between speakers' consensus regarding what variants are considered standard and speakers' use of non-standard, prescriptively stigmatized forms in apparent disregard of the aforementioned standard norm. The positive social value afforded to non-standard and even stigmatized variants, deemed *covert prestige* (cf. Trudgill, 1972), is readily attested for the present data, in that bilingual listeners afforded higher solidarity scores to Catalanian Spanish variants over standard [l] and [s], and moreover speakers explicitly discussed their affinity to 'Catalanized' Spanish inasmuch as it readily indexes a shared or in-group bilingual identity. Indeed, the co-occurrence of negative, prescriptivist stereotypes alongside positive solidarity affirmations is readily predicted in vernacular or folk dialectology: "Areas of great linguistic security find the status dimension strongest; prejudiced-against areas take comfort in solidarity" (Niedzielski & Preston, 1999, p. 366). However, there seems to be an apparent limit when it comes to the social gain of covert solidarity prestige, as Catalan-dominant listeners noted explicit social ridicule for using exaggerated or somehow overly 'Catalanized' Spanish (see [10] in section 5.3). It appears that so long as one's Spanish isn't 'too Catalanized,' it is not subject to chastising within the bilingual speech community and instead is viewed favorably (i.e., covert prestige). Given the observed notoriety of *la ele catalana*, especially when contrasted with the lack of overt awareness of intervocalic [z], it seems reasonable to conclude that Catalanian Spanish [ɫ] is one variant for which the negative social value afforded to it can outweigh its covert prestige in the community.

In studying covert and overt attitudes towards specific speech variants in conjunction with overt attitudes toward Catalanian Spanish overall, it becomes clear that the broader linguistic ideologies regarding Catalanian Spanish are an aggregate product of the individual social values afforded to each and every linguistic variant that comprises it. This is to say that a speaker's evaluation of a language variety as, for example, 'beautiful,' is a generalization made across individual evaluations of 'beauty' for each of its variants, some of which indeed will be judged to be 'beautiful,' while others will be judged to be 'ugly,' and others still will not be associated with 'beauty' either way. For the present data, broader language-level ideologies, such as linguistic cosmopolitanism, are useful for understanding how speakers situate themselves and others with respect to the use of Catalanian

Spanish. However, by additionally examining the attitudes speakers hold with respect to individual linguistic variants of Catalanian Spanish, such as [ɸ] and [z], we see that language- or variety-level ideologies can overlook complex dynamics of social evaluation of, and ultimately use of, discrete linguistic variants. In particular, we have found that the positive esteem toward Catalanian Spanish espoused by linguistic cosmopolitanism is not equally distributed across the set of its variants, such that dark [ɸ] (and surely other variants which we have not investigated presently) is associated with an overly exaggerated and improper ‘Catalanized’ Spanish, resulting in practical, real-world consequences (i.e., public chastising, linguistic insecurity) that could not be otherwise accounted for under a broader-level study of attitudes and ideologies that generalizes across all linguistic variants. Crucially, the negative stigma afforded to [ɸ] in the present dataset does not invalidate or run counter to a broader linguistic ideology like linguistic cosmopolitanism. Rather, it is simply the case that broader language ideologies reflect a quantitative majority of language attitudes towards linguistic variants, which accounts for the presently-observed reality of speakers attributing positive evaluations to Catalanian Spanish while simultaneously attributing strongly negative evaluations to select variants that nonetheless comprise Catalanian Spanish.

7. Conclusion

The present study has sought to examine covert and overt attitudes towards lateral velarization, intervocalic fricative voicing, and Catalanian Spanish using an application of the matched guise methodology that focuses on specific linguistic variants. Reconciling prior attitudinal research on Catalanian Spanish that found, on the one hand, explicit negative associations of Catalanian Spanish with rurality and improper Spanish, and on the other hand, positive evaluations of Catalanian Spanish as part of a linguistic ideology that values bilingualism and language contact effects, we have shown that individual variants of Catalanian Spanish are evaluated uniquely and independently by speakers within and outside of the Catalan-Spanish bilingual community, thus warranting the aforementioned duality of positive and negative evaluations of the variety as a whole. We have presented attitudinal evidence consistent with classifying velarized [ɸ] as a linguistic stereotype and intervocalic [z] as an indicator (cf. Labov, 2001) on the basis of perceptions of solidarity, power, accent, rurality, and bilingualism. In future work, these analyses can be further validated by examining production patterns of /l/ and intervocalic /s/ in Catalanian Spanish with the expectation that their distribution and usage patterns throughout the Catalan-Spanish community be consistent with production patterns typical of sociolinguistic stereotypes and indicators, respectively. Additionally, given the phonetically continuous nature of both phenomena in question, an insightful line of future investigation could entail assessing attitudes towards a series of gradiently darker and lighter laterals and a series of gradiently more or less voiced /s/ productions, facilitating an acoustic pinpointing of how dark or how voiced an /l/ or /s/ (respectively) need to be before listeners perceive them as properly Catalanian, and whether or not these acoustic thresholds (with social consequences) vary by listener group. Finally, it is important to acknowledge that since the Madrid monolingual control group was smaller in size than the rest of the bilingual listener groups, the majority of presented findings reflect the latter group, and accordingly comparisons between Barcelonan bilinguals and Madrid monolinguals could be further validated with an expanded, and crucially more balanced, sample size.

References

- Arnal, A. (2011). Linguistic Changes in the Catalan Spoken in Catalonia under New Contact Conditions. *Journal of Language Contact*, 4, 5-25.
- Badia i Margarit, A. (1964). *Llengua i cultura als Països Catalans*. Edicions 62.
- Badia i Margarit, A. (1984). *Gramàtica històrica catalana*. Tres i Quatre.
- Barnes, S. (2015). Perceptual Salience and Social Categorization of Contact Features in Asturian Spanish. *Studies in Hispanic and Lusophone Linguistics*, 8(2), 213-241.
- Boersma, P. & Weenink, D. (2018). Praat: Doing Phonetics by Computer. [computer software].
- Boix i Fuster, E. & Xavier Vila i Moreno, F. (1998). *Sociolingüística de la llengua catalana*. Ariel Lingüística.
- Bonet, E. & Lloret, M-R. (1998). *Fonologia catalana*. Ariel Lingüística.
- Campbell-Kibler, K. (2006). *Listener Perceptions of Sociolinguistic Variables: The Case of (ING)* (Unpublished doctoral dissertation). Stanford University.
- Campbell-Kibler, K. (2007). Accent, (ING), and the Social Logic of Listener Perceptions. *American Speech*,

82(1), 32-64.

- Campos-Astorkiza, R. (2014). Sibilant Voicing Assimilation in Peninsular Spanish as Gestural Blending. In M-H. Côté & E. Mathieu (Eds.), *Variation Within and Across Romance Languages: Selected Papers from the 41st Linguistic Symposium on Romance Languages* (pp. 17-38). Amsterdam / Philadelphia: John Benjamins Publishing Company.
- Casanovas Català, M. (1995). *La interferència fonètica en el castellà de Lleida: Alguns apuntes para su estudio. Sintagma*, 7, 53-59.
- Chappell, W. & García, C. (2017). Variable Production and Indexical Social Meaning: On the Potential Physiological Origin of Intervocalic /s/ Voicing in Costa Rican Spanish. *Studies in Hispanic and Lusophone Linguistics*, 10(1), 1-37.
- Dalbor, J. B. (1997). *Spanish Pronunciation: Theory and Practice*, 3rd edition. Harcourt Brace College Publishers.
- Davidson, J. (2012). Phonetic Interference of Catalan in Barcelonan Spanish: A Sociolinguistic Approach to Lateral Velarization. In K. Geeslin & M. Díaz-Campos (Eds.), *Selected Proceedings of the 14th Hispanic Linguistics Symposium* (pp. 319-339), Somerville, MA: Cascadilla Press.
- Davidson, J. (2014). A Comparison of Fricative Voicing and Lateral Velarization Phenomena in Barcelona: A Variationist Approach to Spanish in Contact with Catalan. In K. Lahousse and S. Marzo (Eds.), *Romance Languages and Linguistic Theory 2012* (pp. 223-244), Amsterdam / Philadelphia: John Benjamins Publishing Company.
- Davidson, J. (2015). Intervocalic Fricative Voicing in the Spanish of Barcelona: Considerations for Contact-induced Sociophonetic Innovation. In K. Potowski and T. Bugel (Eds.), *Sociolinguistic Change across the Spanish-Speaking World: Case Studies in Honor of Anna Maria Escobar* (pp. 119-146), Peter Lang Publishing.
- Erker, D. (2012). *An Acoustically Based Sociolinguistic Analysis of Variable Coda /s/ Production in the Spanish of New York City* (Unpublished doctoral dissertation). New York University.
- Escalante, C. (2016). Intervocalic Voicing and Regressive Voicing Assimilation in L2 Spanish /s/. *Divergencias*, 14(1), 30-45.
- Ferguson, C. A. (1959). Diglossia. *Word*, 15, 325-340.
- File-Muriel, R. and Brown, E. (2011). The Gradient Nature of s-lenition in Caleño Spanish. *Language Variation and Change*, 23, 223-243.
- Fishman, J. A. (1967). Bilingualism with and without Diglossia. *Journal of Social Issues*, 23(2), 29-38.
- Gifreu, J. (1983). *Sistema i polítiques de la comunicació a Catalunya: Premsa, televisió i cinema. L'Avenç / Col·lecció Clío*.
- Gradoville, M. S. (2011). Validity in Measurements of Fricative Voicing: Evidence from Argentine Spanish. In S. M. Alvord (Ed.), *Selected Proceedings of the 5th Conference on Laboratory Approaches to Romance Phonology* (pp. 59-74). Somerville, MA: Cascadilla Press.
- Hualde, J. I. (1992). *Catalan*. Routledge.
- Hualde, J. I. (2014). *Los sonidos del español*. Cambridge University Press.
- Hualde, J. I. & Prieto, P. (2014). Lenition of Intervocalic Alveolar Fricatives in Catalan and Spanish. *Phonetica*, 71(2), 109-127.
- Institut d'Estadística de Catalunya. (2011). *Territori: Banc d'estadístiques de municipis i comarques*. <<http://www.idescat.cat>>.
- Institut d'Estadística de Catalunya. (2014). *Territori: Banc d'estadístiques de municipis i comarques*. <<http://www.idescat.cat>>.
- Labov, W. (2001). *Principles of Linguistic Change: Volume 2: Social Factors*. Blackwell Publishing.
- Lambert, W. E. (1967). A Social Psychology of Bilingualism. *Journal of Social Issues*, 23, 91-109.
- Lambert, W. E., Hodgson, R. C., Gardner, R. C., & Fillenbaum, S. (1960). Evaluational Reactions to Spoken Languages. *Journal of Abnormal and Social Psychology*, 60(1), 41-61.
- Martínez Celdrán, E. & Fernández Planas, A. M. (2007). *Manual de fonètica espanyola*. Ariel.
- Morgan, T. A. (2010). *Sonidos en contexto: Una introducción a la fonètica del castellà con especial referencia a la vida real*. Yale University Press.
- Navarro Tomás, T. (1918). *Manual de pronunciación espanyola*. Imprenta de los Sucesores de Hernando.
- Newman, M. (2011). Different Ways to Hate a Language in Catalonia: Interpreting Low Solidarity Scores in Language Attitude Studies. In J. Michnowicz & R. Dodsworth (Eds.), *Selected Proceedings of the 5th Workshop on Spanish Sociolinguistics* (pp. 40-49). Somerville, MA: Cascadilla Press.
- Newman, M., Trenchs-Parera, M., & Ng, S. (2008). Normalizing Bilingualism: The Effects of the Catalan Linguistic Normalization Policy One Generation After. *Journal of Sociolinguistics*, 12(3), 306-333.
- Niedzielski, N. & Preston, D. R. (1999). *Folk Linguistics*. Berlin/New York: Mouton de Gruyter.
- Pieras, F. (1999). *Social Dynamics of Language Contact in Palma de Mallorca: Attitude and Phonological Transfer* (Unpublished doctoral dissertation). Pennsylvania State University.
- Prieto, P. (2004). *Fonètica i fonologia. Els sons del català*. Editorial UOC.
- Proctor, M. I. (2009). *Gestural Characterization of a Phonological Class: The Liquids* (Unpublished doctoral dissertation). Yale University.

- Quilis, A. (1981). *Fonètica acústica de la lengua española*. Gredos.
- R Core Team. (2018). R: A Language and Environment for Statistical Computing. R Foundation for Statistical Computing. Vienna, Austria. <<http://www.R-project.org/>>
- Recasens, D. (1986). *Estudis de fonètica experimental del català oriental central*. Publicacions de l'Abadia de Montserrat.
- Recasens, D. (1991). *Fonètica descriptiva del català: Assaig de la pronúncia del vocalisme i consonantisme del català al segle XX*. Institut d'Estudis Catalans.
- Recasens, D. (1996). An Articulatory-perceptual Account of Vocalization and Elision of Dark /l/ in the Romance Languages. *Language and Speech*, 39(1), 63-89.
- Recasens, D. (2004). Darkness in [l] as a Scalar Phonetic Property: Implications for Phonology and Articulatory Control. *Clinical Linguistics and Phonetics*, 18(6-8), 593-603.
- Recasens, D. (2012). A Cross-Language Acoustic Study of Initial and Final Allophones of /l/. *Speech Communication*, 54, 368-383.
- Recasens, D. (2014). *Fonètica i fonologia experimentals del català: Vocals i consonants*. Institut d'Estudis Catalans.
- Recasens, D. & Espinosa, A. (2005). Articulatory, Positional and Coarticulatory Characteristics for Clear /l/ and Dark /l/: Evidence from Two Catalan Dialects. *Journal of the International Phonetic Association*, 35(1), 1-25.
- Recasens, D., Fontdevila, J., & Pallarès M. D. (1995). Velarization Degree and Coarticulatory Resistance for /l/ in Catalan and German. *Journal of Phonetics*, 23, 37-52.
- Rivas, M. V. (2006). *Does the Perception of Fricatives Correspond to their Production? The Case of Italian vs. Dutch* (Unpublished master's dissertation). University of Amsterdam.
- Romero, J. (1999). The Effect of Voicing Assimilation on Gestural Coordination'. In J.J. Ohala, Y. Hasegawa, M. Ohala, D. Granvill, & A.C. Bailey (Eds.), *Proceedings of the 14th International Congress of Phonetic Sciences* (pp. 1793-1796). American Institute of Physics.
- Ryan, E. B. (1979). Why Do Low-prestige Languages Varieties Persist?. In H. Giles and R. N. St Clair (Eds.), *Language and Social Psychology* (pp. 145-157). Baltimore: University Park Press.
- Sanz i Alcalà, C. (1991). *Actituds envers les varietats bilingües i monolingües del castellà a Barcelona*. *Catalan Review*, 5(2), 121-136.
- Schmidt, L. B. & Willis E. W. (2011). Systematic Investigation of Voicing Assimilation of Spanish /s/ in Mexico City'. In S. M. Alvord (Ed.), *Selected Proceedings of the 5th Conference on Laboratory Approaches to Romance Phonology* (pp. 1-20). Somerville, MA: Cascadilla Press.
- Schwegler, A., Kempff, J., & Ameal-Guerra, A. (2010). *Fonètica y fonología españolas*. 4th edition. John Wiley & Sons, Inc.
- Seib, J. (2001). *La variedad bilingüe del español hablado en Cataluña caracterizada por interferencias y convergencias con el catalán* (Unpublished doctoral dissertation). Universität Mannheim.
- Serrano Vázquez, M. (1996). *Rasgos fonéticos del carácter interferencial en el castellano de una comunidad bilingüe*. *Estudios de Lingüística: Universidad de Alicante*, 11, 365-383.
- Simonet, M. (2010a). Dark and Clear Laterals in Catalan and Spanish: Interaction of Phonetic Categories in Early Bilinguals. *Journal of Phonetics*, 38: 663-678.
- Simonet, M. (2010b). Laterals in Majorcan Spanish. Effects of Contact with Catalan?. In S. Colina, A. Olarrea, & A. Carvalho (Eds.), *Romance Linguistics 2009: Selected Papers from the 39th Linguistic Symposium on Romance Languages* (pp. 81-94). Amsterdam: John Benjamins.
- Sinner, C. (2002). The Construction of Identity and Group Boundaries in Catalan Spanish. In A. Duszak (Ed.), *Us and Others: Social Identities across Languages, Discourses and Cultures* (pp. 159-185). Philadelphia, PA: John Benjamins Publishing Company.
- Stevens, K., Blumstein, S., Glicksman, L., Burton, M., & Kurowski, K. (1992). Acoustic and Perceptual Characteristics of Voicing in Fricatives and Fricative Clusters. *Journal of the Acoustical Society of America*, 91(5), 2979-3000.
- Strubell i Trueta, M. (1984). Language and Identity in Catalonia. *International Journal of the Sociology of Language*, 47, 91-104.
- Torreira, F. and Ernestus, M. (2012). Weakening of Intervocalic /s/ in the Nijmegen Corpus of Casual Spanish. *Phonetica*, 69, 124-148.
- Trenchs-Parera, M. & Newman, M. (2009). Diversity of Language Ideologies in Spanish-speaking Youth of Different Origins in Catalonia. *Journal of Multilingual and Multicultural Development*, 30(6), 509-524.
- Trudgill, P. (1972). Sex, covert prestige and linguistic change in the urban British English of Norwich. *Language in Society*, 1, 179-195.
- Turell Julià, M. T. (2000). More on the Interplay between Internal and External Factors: Dialect Convergence and Divergence of Catalan. In K. Mattheier (Ed.), *Dialect and Migration in a Changing Europe* (pp. 43-56). Frankfurt am Main: Peter Lang Publishing.
- Vallverdú, F. (1984). A Sociolinguistic History of Catalan. *International Journal of the Sociology of Language*, 47, 13-28.

- Vallverdú, F. (1991). *Los estudios sociolingüísticos en España, especialmente en Cataluña*. In C. Klee (Ed.), *Sociolinguistics of the Spanish-speaking World: Iberia, Latin America, United States* (pp. 15-40). Tempe: Bilingual Press.
- Vann, R. E. (1999). Reversal of Linguistic Fortune: Dimensions of Language Conflict in Autonomous Catalonia. *Language & Communication, 19*, 317-327.
- Vann, R. E. (2000). Constructing Reality in Bicultural Communication: Catalan Ways of Speaking Spanish. *Intercultural Communication Studies, 10(1)*, 113-124.
- Vann, R. E. (2001). *El castellà catalanitzat a Barcelona: Perspectives lingüístiques i culturals*. *Catalan Review, 15(1)*, 117-131.
- Vann, R. E. (2002). Card-carrying Catalans and 'Las diez normas que hay que seguir para ser un buen catalán'. *Catalan Review, 16(1-2)*, 207-219.
- Vann, R. E. (2007). Constructing Catalanism: Motion Verbs, Demonstratives, and Locatives in the Spanish of Barcelona. In M. Azevedo, A. Bastardas, E. Boix, and P. E. O'Donell (Eds.), *Catalan Review: Sociolinguistics* (pp. 253-274), *9(2)*, Barcelona: North American Catalan Society.
- Vila-Pujol, M. R. (2007). Sociolinguistics of Spanish in Catalonia. *International Journal of the Sociology of Language, 184*, 59-77.
- Wesch, A. (1997). *El castellano hablado de Barcelona y el influjo del catalán: Esbozo de un programa de investigación*. *Anuario Galego de Filoloxía (VERBA), 24*, 287-312.
- Wheeler, M. W. (2005). *The Phonology of Catalan*. Oxford University Press.
- Woolard, K. A. (1984). A Formal Measure of Language Attitudes in Barcelona: A Note from Work in Progress. *International Journal of the Sociology of Language, 47*, 63-71.
- Woolard, K. A. (1989). *Double Talk: Bilingualism and the Politics of Ethnicity in Catalonia*. Stanford University Press.
- Woolard, K. A. (2009). Linguistic Consciousness Among Adolescents in Catalonia: A Case Study from the Barcelonan Urban Area in Longitudinal Perspective. *Zeitschrift für Katalanistik, 22*, 125-149.
- Woolard, K. A. (2011). Is There Life after High School? Longitudinal Changes in the Bilingual Repertoire in Metropolitan Barcelona. *Language in Society, 40*, 617-648.
- Woolard, K. A. & Gahng, T-J. (1990). Changing Language Policies and Attitudes in Autonomous Catalonia. *Language in Society, 19(3)*, 311-330.

Appendix A – Guise Passages

/l/ - Ayer, no tenía ganas de despertarme para nada. Sonó mi despertador y vi que el sol todavía no había aparecido. Después de ir al baño, me preparé un café y también algo de comer. Sonó mi móvil mientras caminaba al comedor - era un amigo mío. Me dijo que el jueves quería ir con alguien a ver un concierto donde iba a tocar nuestra amiga. Pensaba que estaría muy triste si no fuéramos. Al final, decidí ir, entonces fuimos juntos.

‘Yesterday, I didn’t feel like waking up at all. My alarm clock went off and I saw that the sun still had not appeared. After going to the bathroom, I made myself a coffee and also something to eat. My cell phone rang while I was walking to the dining room - it was a friend of mine. He told me that on Thursday he wanted to go with somebody to see a concert where our friend was going to play. He thought she would be really sad if we didn’t go. In the end, I decided to go, so we went together.’

/s/ - Hoy es un día bonito. Después de un invierno muy frío, ya estamos en primavera. Si vas afuera, notarás en seguida que nadie tiene puesto un abrigo. Dentro de poco, voy con unos amigos a tomar un café, que ya hace mucho que no nos hemos visto todos juntos. Aunque típicamente vamos a un sitio aquí cerca, esta vez queremos encontrar otro por ahí. Como he dicho, hoy tenemos un día perfecto para ir a andar un poco.

‘Today is a beautiful day. After a very cold winter, we are finally in spring. If you go outside, you’ll immediately notice that nobody is wearing a coat. In a little bit, I am going with some friends for a coffee; it’s been a while since we’ve last seen each other all together. Although we typically go to a place here nearby, this time we want to find some other around there. As I said, today we have a perfect day for going to walk a bit.’

Filler A - *Un día, estaba caminando por el parque cuando empezó a llover. No había traído mi paraguas, entonces no tenía más remedio que ponerme al lado de un árbol grande, bajo las ramas y las hojas. Por suerte, dejó de llover después de unos diez minutos y no estaba tan empapado/a. Volví a pasear, y al de poco salió el sol y hacía buen tiempo. Decidí regresar a casa a pie, aprovechando el tiempo tan agradable.*

‘One day, I was walking through the park when it started to rain. I hadn’t brought my umbrella, so I didn’t have any other option other than to put myself next to a big tree, under the branches and leaves. Luckily, it stopped raining after about 10 minutes and I wasn’t so soaked. I returned to my walk, and soon the sun came out and the weather was nice. I decided to go home by foot, to enjoy the really nice weather.’

Filler B - *A veces cuando quiero relajarme, me gusta ir a la playa. Me encanta caminar por la arena y descansar bajo el sol. Si hace mucho calor, me meto en el agua por un rato. Muchas veces voy a una playa específica con un grupo de amigos, donde pasamos unas horas relajándonos, pero a veces cuando quiero un poco más de paz, voy a otra playa donde no suele haber mucha gente. Siempre me quita todo el estrés.*

‘Sometimes when I want to relax, I like to go to the beach. I love walking along the sand and relaxing under the sun. If it’s really hot, I hop in the water for a bit. I often go to a specific beach with a group of friends, where we spend hours relaxing, but sometimes when I want a little more peace, I go to another beach where there usually aren’t ever many people. It always gets rid of all my stress.’

Filler C - *Recuerdo que el otro día necesitaba comprar unas manzanas rojas en el supermercado. Como siempre tienen manzanas, no había pensado ir a comprarlas hasta la tarde. Así, a las cuatro salí de casa y fui al supermercado. Fui directamente a la sección de fruta y, vaya sorpresa; ¡no tenían ninguna! Busqué durante unos cinco minutos antes de admitir que realmente se les habían acabado. Decidí ir a otro supermercado un poco más lejos, y no llegué a casa hasta las seis.*

‘I remember that the other day I needed to buy some red apples at the supermarket. Since they always have apples, I didn’t think to go buy them until the afternoon. So, at 4 I left my house and went to the supermarket. I went directly to the fruit section and, go figure; they didn’t have any! I looked for some 5 minutes before admitting that they really had run out of them. I decided to go to another supermarket a little farther away, and I didn’t arrive back at home until 6.’

Filler D - *El otro día, tuve una muy mala experiencia en un restaurante. Primero, cuando llegué, el sitio estaba tan lleno de gente que no había espacio para esperar adentro, entonces esperé afuera donde hacía bastante calor. Luego, cuando pedí mi plato favorito, me dijo el camarero que se les habían acabado los ingredientes, entonces tuve que pedir otro. Después, debido a algún problema con la estufa en la cocina, tardaron media hora para traer la comida. Qué mala suerte, ¿no?*

‘The other day, I had a really bad experience at a restaurant. First, when I arrived, the place was so full of people that there wasn’t room to wait inside, so I waited outside where it was pretty hot. Later, when I ordered my favorite dish, the waiter told me that they had run out of the ingredients, so I had to order another

one. After, because of some problem with the stove in the kitchen, they took 30 minutes to bring the food. What bad luck?’

Appendix B – Matched Guise Questionnaire

Instrucciones: A continuación vas a escuchar a una serie de personas diferentes que no conoces hablando en castellano. Verás una lista de características que tendrás que atribuir a una y cada persona que escuches. Basándote en la escala del 1 al 7, indica tu opinión acerca de la persona que escuches.

‘Instructions: You are about to listen series of individuals, who you have never met before, speak in Spanish. Below is a list of several characteristics that you will attribute to the speaker you hear. Using the 1-7 scale, indicate your opinion about the person you hear.’

Por ejemplo, si después de escuchar a la persona piensas que es simpática, indica con un círculo el número “7” que marca “simpática.” Si por el contrario piensas que la persona es antipática, indica un “1” que marca “antipática.” Utiliza el número “4” si no tienes ninguna opinión si esta persona es simpática o antipática.

‘For example, if after listening to the person you think that s/he is nice, circle the number 7 that indicates ‘nice.’ If on the other hand you think that the person is mean, circle the number 1 that indicates ‘mean.’ Use the number 4 if you don’t have an opinion about if the person is nice or mean.’

Pienso que esta persona (es).... ‘I think that this person (is)....’

1) SOLIDARITY

antipática
‘mean’

1 2 3 4 5

simpática
‘nice’

6 7

7) RURALITY

de la ciudad
‘from the city’

1 2 3 4

del campo
‘from the countryside’

5 6 7

2) POWER

tiene estudios
‘educated’

1 2 3 4 5

no tiene estudios
‘uneducated’

6 7

8) BILINGUALISM

también habla catalán
‘also speaks Catalan’

1 2 3 4

sólo habla castellano
‘only speaks Spanish’

5 6 7

3) ACCENT

sabe hablar castellano bien
‘speaks Spanish well’

1 2 3 4 5

no sabe hablar castellano bien
‘does not speak Spanish well’

6 7

9) SOLIDARITY

desagradable de escuchar
‘unpleasant to listen to’

1 2 3 4

agradable de escuchar
‘pleasant to listen to’

5 6 7

4) [filler]

sólo habla castellano
‘only speaks Spanish’

1 2 3 4 5

también habla vasco
‘also speaks Basque’

6 7

10) POWER

fiable
‘trustworthy’

1 2 3 4

dudosa
‘untrustworthy’

5 6 7

5) SOLIDARITY

no sería mi amigo/a fácilmente
‘would not easily be my friend’

1 2 3 4 5

sería mi amigo/a fácilmente
‘would easily be my friend’

6 7

11) ACCENT

tiene un acento bonito
‘has a pretty accent’

1 2 3 4

tiene un acento feo
‘has an ugly accent’

5 6 7

6) POWER

tiene un trabajo que le pagan bien

tiene un trabajo que le pagan mal

12) [filler]

sólo habla castellano

también habla gallego

'has a high-paying job'

1 2 3 **4**

5

'has a low-paying job'

6 **7**

'only speaks Spanish'

1 2 3 **4**

5

'also speaks Galician'

6 **7**